

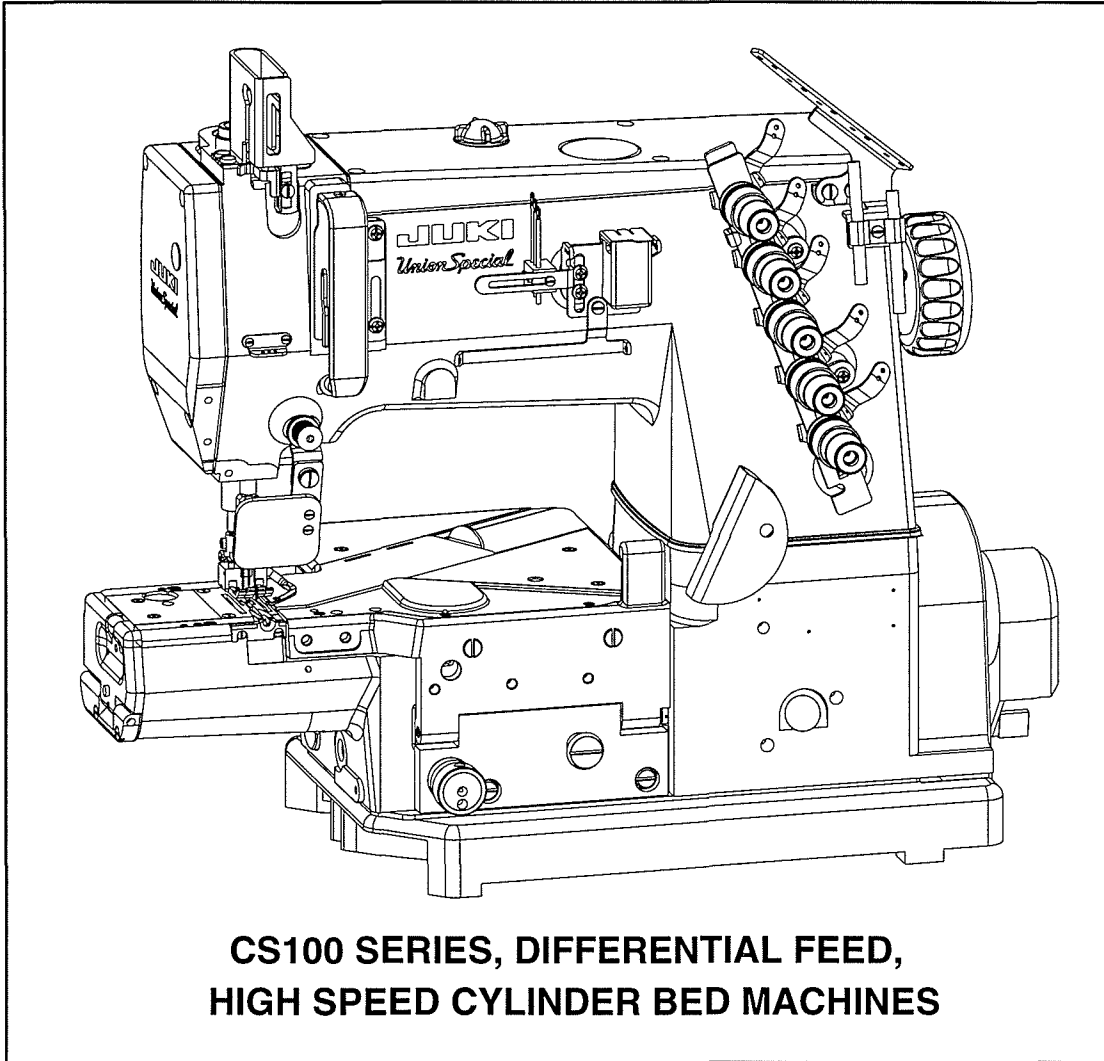

JUKI
Union Special

ADJUSTING INSTRUCTION / PARTS MANUAL



**CS100 SERIES, DIFFERENTIAL FEED,
HIGH SPEED CYLINDER BED MACHINES**

**MANUAL NO. PT9802
FOR DEVICES**

UT1CS1
UT2CS1
UT3CS1
UT4CS1
UT5CS1

USE IN CONJUNCTION WITH MACHINE SERIAL NUMBER PREFIX (BG) AND LATER

Adjusting Instructions/Parts Manual PT9802 for Devices UT1CS1, UT2CS1, UT3CS1, UT4CS1, UT5CS1

First Edition Copyright 1998 by Union Special Corporation
Rights Reserved In All Countries Printed in U.S.A. July 1998

PREFACE

This parts manual has been prepared to assist you in locating NEW individual parts or assemblies on the CS100 Series machines. It can be used in conjunction with Union Special Parts Manuals PT9801 & Operator's Manual OP9637.

It is the desire of Union Special that each machine run at its optimum performance. Parts listed in this manual are designed specifically for your machine and are manufactured with utmost precision to assure long lasting service.

This manual has been comprised on the basis of available information. Changes in design and/or improvements may incorporate a slight modification of configuration in illustrations or part numbers.



CONTENTS

PREFACE	2
SAFETY RULES	4
TENSION RELEASE (UNDERBED THREAD TRIMMER)	5
THREAD PULL-OFF	6
THREADING DIAGRAM	7
UNDERBED THREAD TRIMMER (ELECTRIC)	8
UNDERBED THREAD TRIMMER ASSEMBLY	9
UNDERBED THREAD TRIMMER ASSEMBLY	10
UNDERBED THREAD TRIMMER ASSEMBLY	11
UPPER KNIFE AND CLAMPING SPRING	11
TENSION SPRING	11
UNDERBED THREAD TRIMMER ASSEMBLY	12
LOWER KNIFE FRONT TO BACK	12
STOP DISTANCE	12
GUIDE DISTANCE	12
UNDERBED THREAD TRIMMER	13
ELECTROPNEUMATIC DRIVE	13
SETTING PROXIMITY SWITCH	14
SOLENOID/PNEUMATIC THREAD WIPER	15
ADJUSTING THREAD WIPER	16
PNEUMATIC/ELECTRIC COVER THREAD TRIMMER	17
NEEDLE THREAD BLOWER ASSEMBLY	17
AIR FLOW	17
THREAD TENSION	19
UNDERBED THREAD TRIMMER ASSEMBLY	21
ELECTRIC PRESSER FOOT LIFTER ASSEMBLY	23
ELECTRIC THREAD WIPER ASSEMBLY	25
ELECTRIC DRIVE DOUBLE ACTION ASSEMBLY	27
ELECTRIC SPREADER THREAD TRIMMER ASSEMBLY	29
PNEUMATIC CONTROL	31
PNEUMATIC DRIVE DOUBLE ACTION ASSEMBLY	33
PNEUMATIC THREAD WIPER ASSEMBLY	35
PRESSER FOOT LIFTER	37
NEEDLE THREAD BLOWER ASSEMBLY	39
PNEUMATIC SPREADER THREAD TRIMMER ASSEMBLY	41
NUMERICAL INDEX OF PARTS	47
NUMERICAL INDEX OF PARTS	48
NOTES	49



SAFETY RULES

1. Before putting the machines described in this manual into service, carefully read the instructions. The starting of each machine is only permitted after taking notice of the instructions and by qualified operators.

IMPORTANT! Before putting the machine into service, also read the safety rules and instructions from the motor supplier.

2. Observe the national safety rules valid for your country.
3. The sewing machines described in this instruction manual are prohibited from being put into service until it has been ascertained that the sewing units which these sewing machines will be built into, have conformed with the EC Council Directives (89/392/EEC, Annex II B).

Each machine is only allowed to be used as foreseen. The foreseen use of the particular machine is described in paragraph "STYLES OF MACHINES" of this instruction manual. Another use, going beyond the description, is not as foreseen.

4. All safety devices must be in position when the machine is ready for work or in operation. Operation of the machine without the appertaining safety devices is prohibited.
5. Wear safety glasses.
6. In case of machine conversions and changes all valid safety rules must be considered. Conversions and changes are made at your own risk.
7. The warning hints in the instructions are marked with one of these two symbols:



8. When doing the following the machine has to be disconnected from the power supply by turning off the main switch or by pulling out the main plug:
 - 8.1 When threading needle(s), looper, spreader etc.
 - 8.2 When replacing any parts such as needle(s), presser foot, throat plate, looper, spreader, feed dog, needle guard, folder, fabric guide etc.
 - 8.3 When leaving the workplace and when the workplace is unattended.
 - 8.4 When doing maintenance work.
 - 8.5 When using clutch motors without actuation lock, wait until the motor is stopped totally.
9. Maintenance, repair and conversion work (see item 8) must be done only by trained technicians or special skilled personnel under consideration of the instructions.
10. Any work on the electrical equipment must be done by an electrician or under direction and supervision of special skilled personnel.
11. Work on parts and equipment under electrical power is not permitted. Permissible exceptions are described in the applicable sections of standard sheet DIN VDE 0105.
12. Before doing maintenance and repair work on the pneumatic equipment, the machine has to be disconnected from the compressed air supply. In case of existing residual air pressure after disconnecting from compressed air supply (i.e. pneumatic equipment with air tank), the pressure has to be removed by bleeding.



TENSION RELEASE (UNDERBED THREAD TRIMMER)

Set separators (C) as close to tension discs (D) without touching them and not to bind when fully extended.

Tension discs (D) must open as soon as cutting process begins.

Tension disc separators (C) should move freely between tension discs (D) without binding.

Thread trimmer and tension release assemblies are linked together.

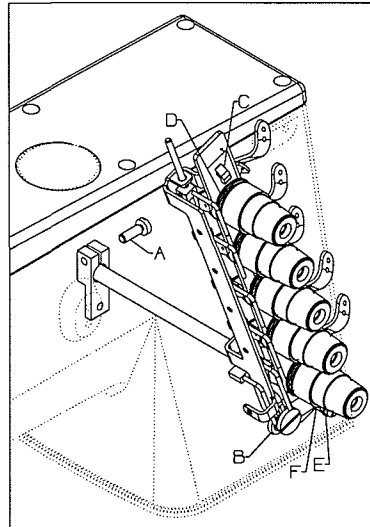

TO ADJUST:

Loosen screw (E).

Turn eccentric (F), located behind screw (E) to set tension release lever (B) as required.

Retighten screw (E).

After adjustment there should be no binding at any point.

Adjust the tension release lever (A) to fully open the tension release and return without binding. The tension release is timed with the activation of the fabric thread trimmer.

THREAD PULL-OFF

Pull-off hooks (B) for needle threads, control length of needle thread tails on a garment after trimming.

Set hooks (B) to strike-off shortest tail possible and still start sewing within the first or second stitch.

Set thread pull-off hook (C), for spreader thread so that thread is clamped securely when trimmed and starts properly when the stitch is first started. Lowering the needle thread pull off hooks will strike off more thread leaving longer tails.

Set hook (D), for the looper thread so that the thread is clamped securely when trimmed.

NOTE: Moving strike-off hooks down strikes off more thread. Moving strike-off hooks up strikes off less thread.

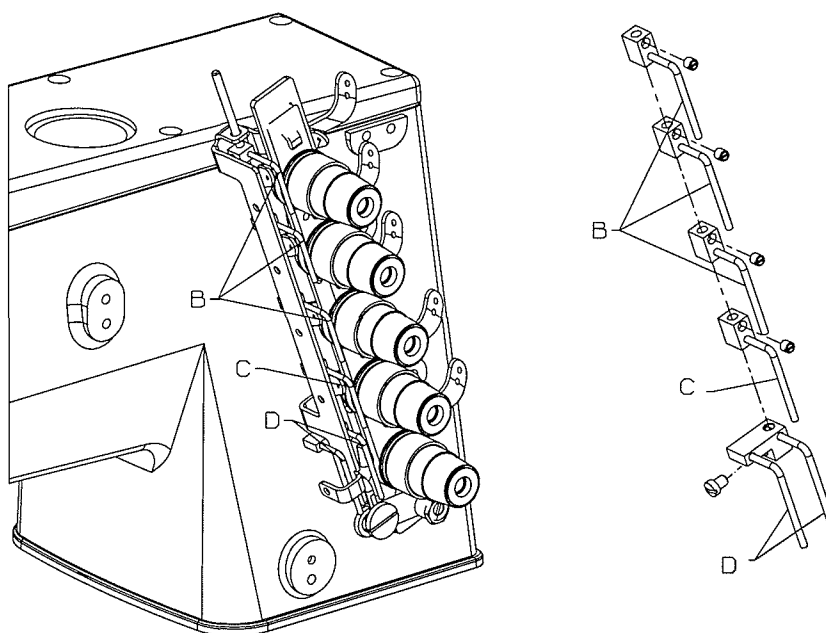

THREADING DIAGRAM
Looper Thread Strike-Off

CAUTION: Improper threading may cause; looper thread wrap-ups or inconsistent start of stitches.

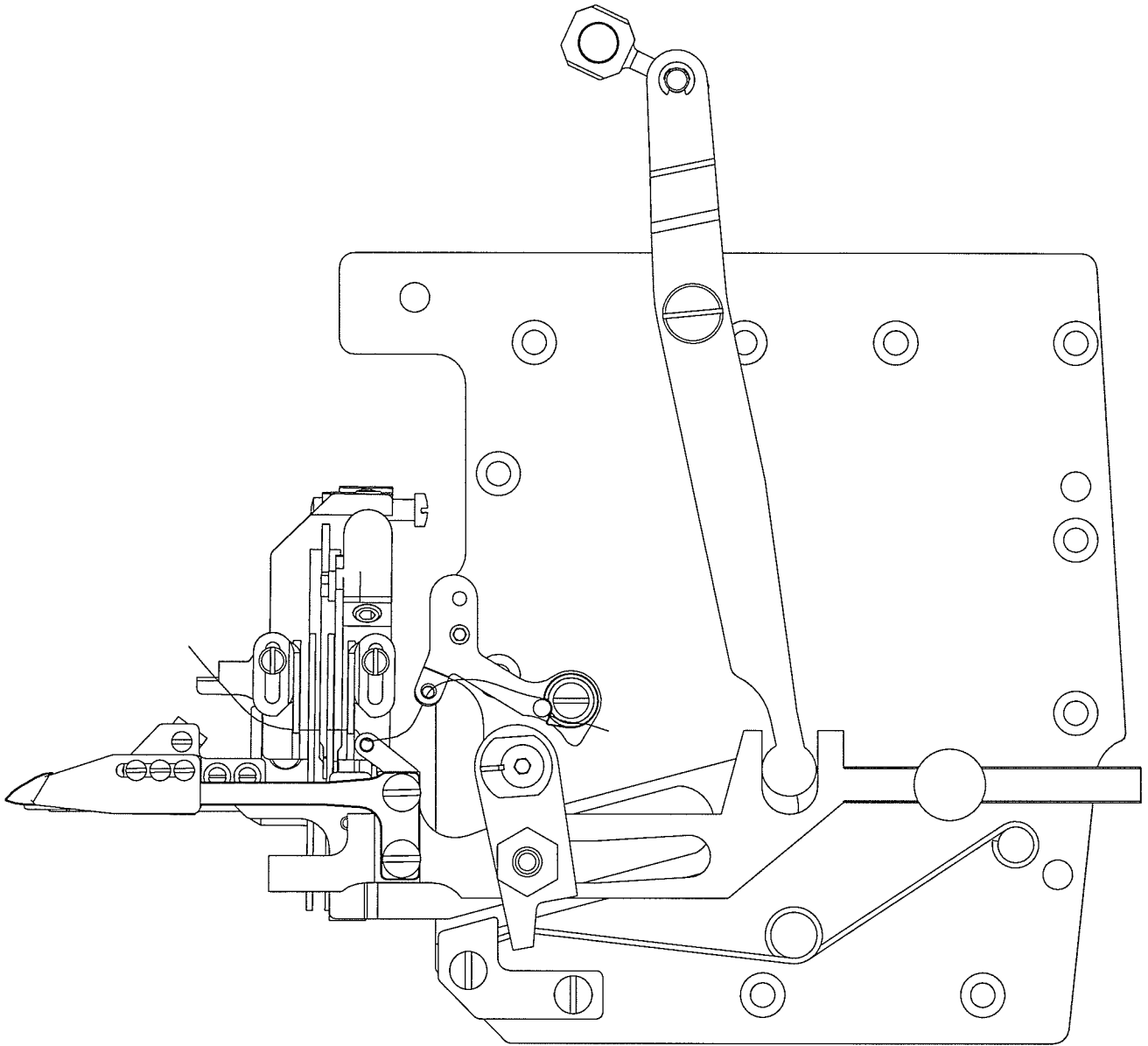

UNDERBED THREAD TRIMMER (ELECTRIC)

Set stroke of the driving solenoid to: $45/64$ " (18mm). All gauges.

Remove the cloth plate.

Loosen nut (A).

Move crosshead (B) on shaft (C) as required.

Retighten nut (A).

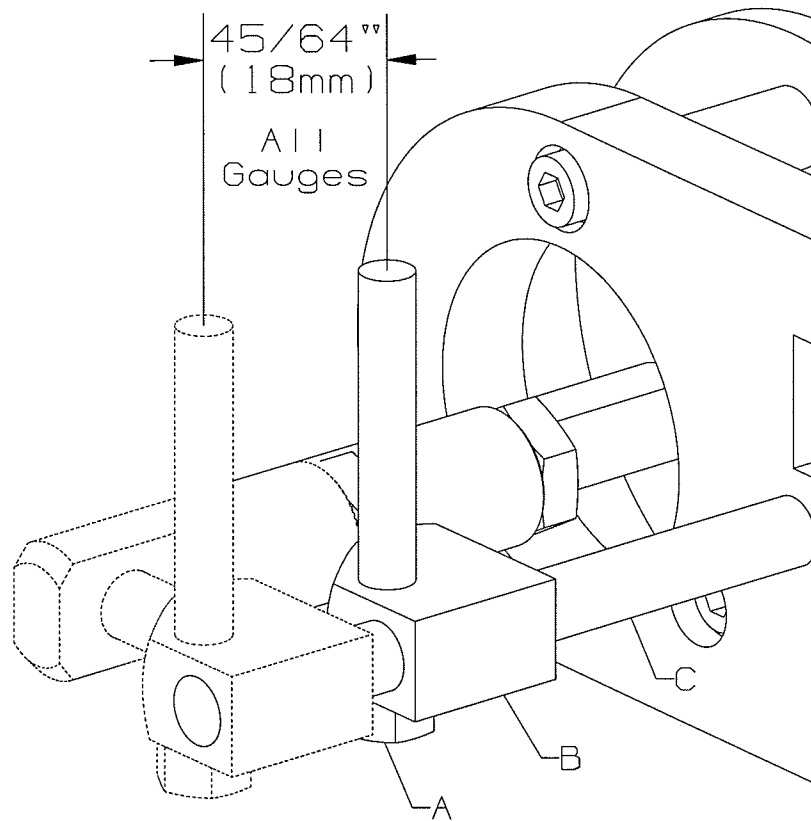

UNDERBED THREAD TRIMMER ASSEMBLY

When the thread trimmer is in its home position, the distance between edge (AA) and the protruding edge of lever (D) should be: $1/64''$ (0.4mm).

Remove retainer ring (E).

Push down on driving link to remove from hole in arm (G).

Turn driving link (F) in or out as required.

Release driving link (F) making sure pin is in hole in arm (G).

Replace retainer ring (E).

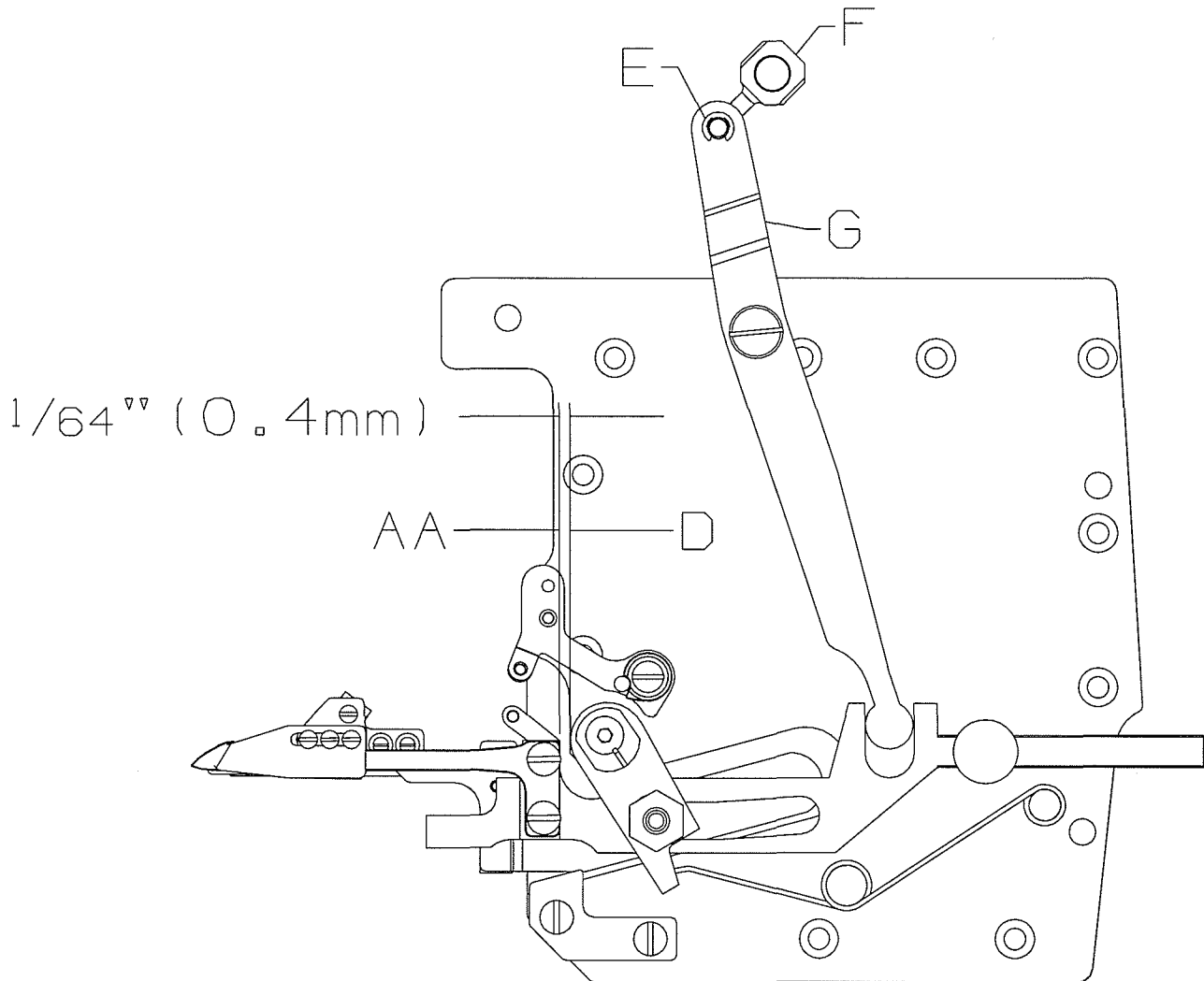

UNDERBED THREAD TRIMMER ASSEMBLY

Knife Adjustment

When positioning lower knife (G), eyelet (J) must be seated to the right.

Lower knife (G) must be seated to the right and all the way forward when tightened.

Loosen 2 screws (K).

Move eyelet (J) to the right as required.

Set lower knife as required.

Retighten screws (K).

To ensure no binds, extend knife (G) to the left and loosen upper knife screws (H) at the same time.

Retighten screws (H).

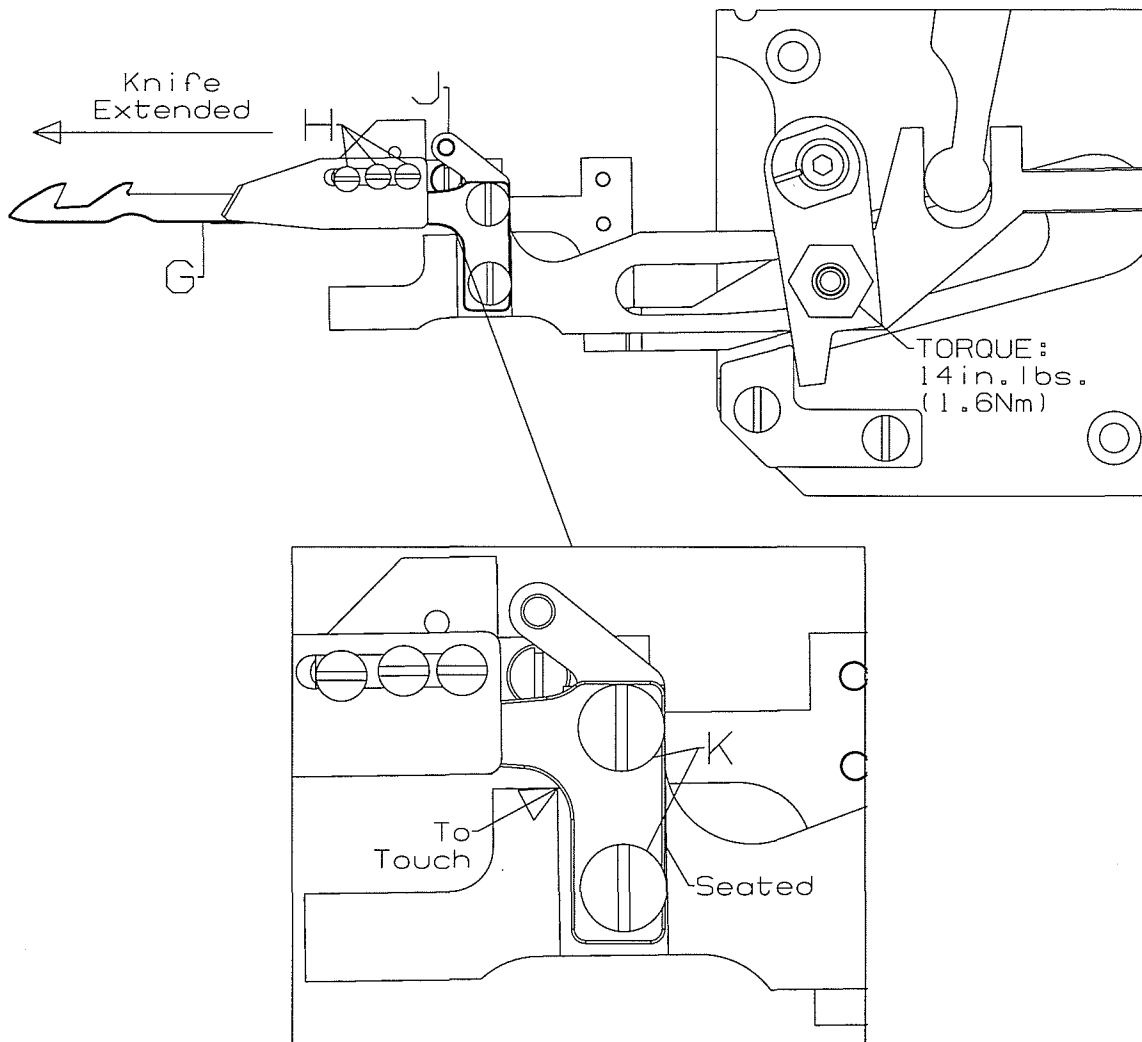

UNDERBED THREAD TRIMMER ASSEMBLY

Upper knife (L) should overlap lower knife (G) by: .020" (0.5mm).

The distance from clamping leaf spring (N) to the tip of lower knife (G) should be: 1/8" (3mm). Clamping leaf spring (N) should be flush with knife at edge (BB).

NOTE: The clamping leaf spring must be set to only clamp the looper thread, NOT the needle threads.

The distance from tension leaf spring (M) to the back of upper knife (L, @ point CC) should be: .020" (0.5mm) to .040" (1.0mm).

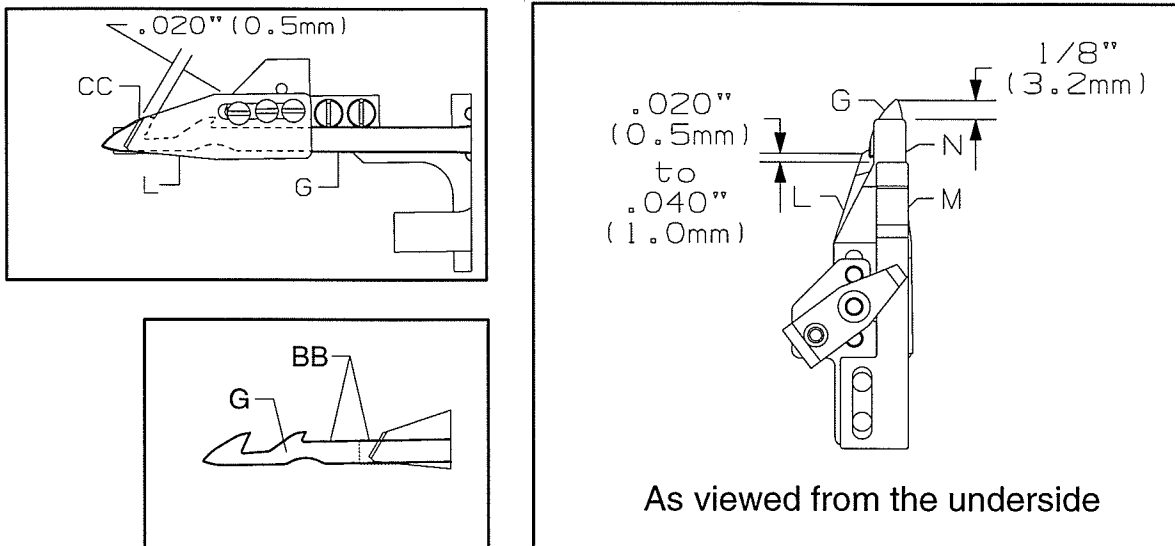

UPPER KNIFE AND CLAMPING SPRING

Loosen two screws (H) and screw (H1).

Move upper knife (L) and clamping leaf spring (N) as required.

Retighten screws (H) and (H1).

TENSION SPRING

Loosen two screws (P).

Adjust leaf spring (M) as required.

Retighten screws.

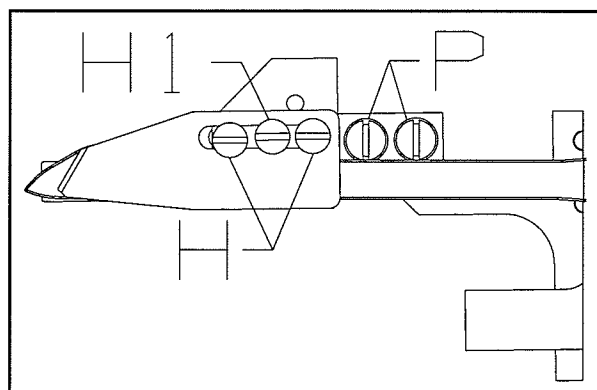

UNDERBED THREAD TRIMMER ASSEMBLY

With the needles at top dead center: Lower knife (G) should be extended past the heel of looper (Q) by: 15/32" (12.0mm), for the following adjustments.

The tip of lower knife (G) should be centered front to back, to the rear edge of the flat on top of looper (Q).

Stop (R) sets the distance of the upper knife and springs to the looper, it should be centered in its slots.

Guide (S) should just contact edge (DD) of knife mechanism.

On cover stitch machines (G) should be set slightly rearward .005" (.10mm) of the standard adjustment.

The bottom of lower knife (L) should clear looper (Q) by .004" (0.1mm).

LOWER KNIFE FRONT TO BACK

Loosen screw (T).

Move eccentric (U) as required.

Retighten screw (T).

STOP DISTANCE

Loosen screws (V).

Move stop (R) as required.

Retighten screws (V).

GUIDE DISTANCE

Loosen screws (W).

Move guide (S) as required to just contact edge (DD).

Retighten screws (W).

Loosen screws (W). Move guide (S) as required to obtain .004" (0.1mm) dimension.

Retighten screws (W).

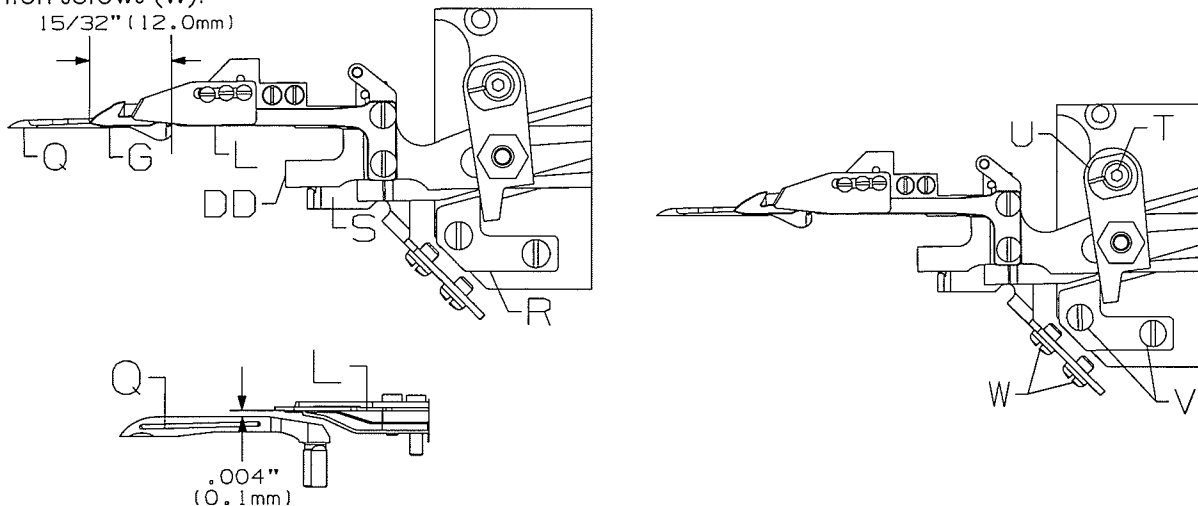

UNDERBED THREAD TRIMMER

ELECTROPNEUMATIC DRIVE

Adjust the metering screws so that thread trimmer mechanism and knife move smoothly left to right and the threads are cleanly cut and clamped.

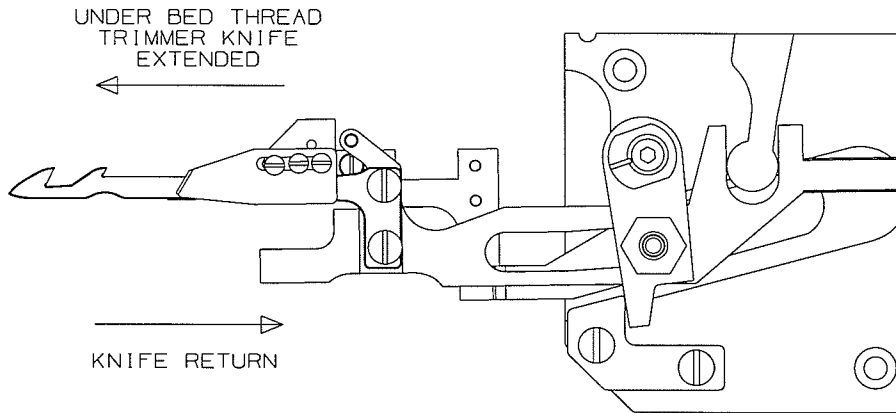

To increase the speed of the knife return, turn screw (A) counterclockwise.

To decrease the speed of the knife, turn screw (A) clockwise.

To increase the speed of extending the knife, turn screw (B) counterclockwise.

To decrease the speed of extending the knife, turn screw (B) clockwise.

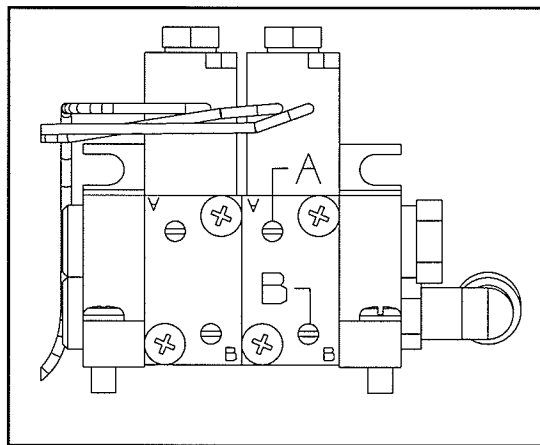

SETTING PROXIMITY SWITCH

Proximity switch prevents motor from running when thread trimmer mechanism is not in extreme right position.

When moving thread trimmer mechanism 0.020" (0.5mm) to left LED must go out, motor will not start.

Move thread trimmer mechanism to its extreme right (end) position.

Switch on motor (do not run).

Loosen nuts (B).

Adjust switch (A) closer to lever (C) until LED illuminates.

Distance should be between 0.020 to 0.032" (0.5 to 0.8mm).

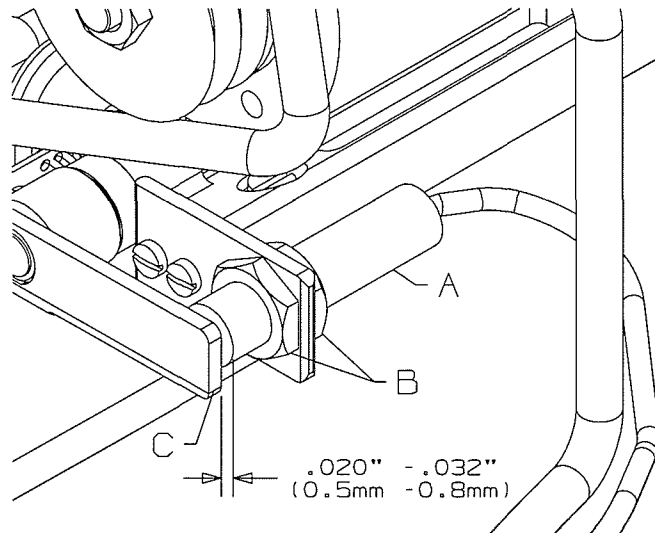

SOLENOID/PNEUMATIC THREAD WIPER

Bracket installed at 90 angle to needles.

Wiper hook (A) must deflect needle threads to operator on downstroke, (Fig. 1). Also the catch of the hook must pass the left needle by $1/8"$ (3.0mm).

On return, wiper hook must catch all needle threads (Fig. 2) and draw them into leaf spring (B) to be clamped.

Wiper hook (A) and leaf spring (B) should be flush at point (C) when at rest position.

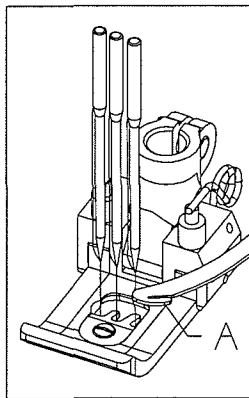
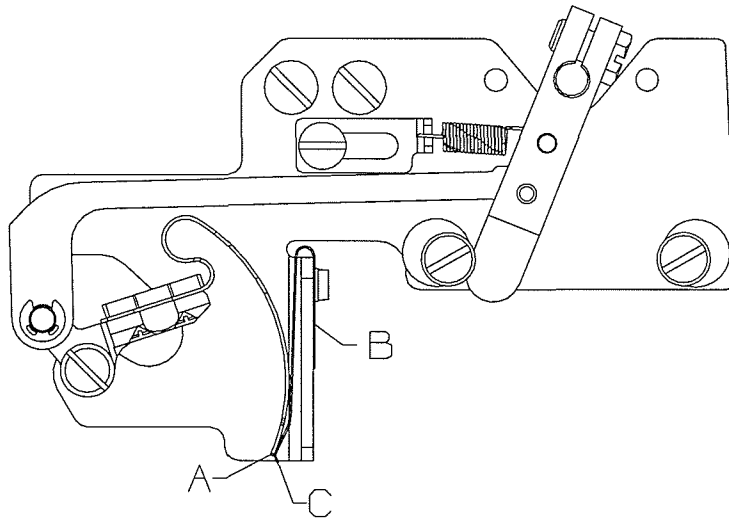

FIG. 1

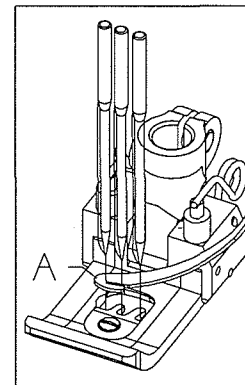
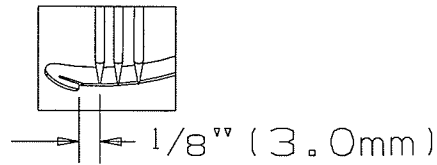

FIG. 2

ADJUSTING THREAD WIPER

Disconnect power supply for thread wiper.

Loosen screws (D). Move wiper (A) left or right as necessary.

Retighten screws (D).

Operate wiper manually to check adjustment.

Loosen screw (E), move leaf spring (B) flush with wiper (A) at point (C).

Retighten screw (E).

Reconnect power supply.

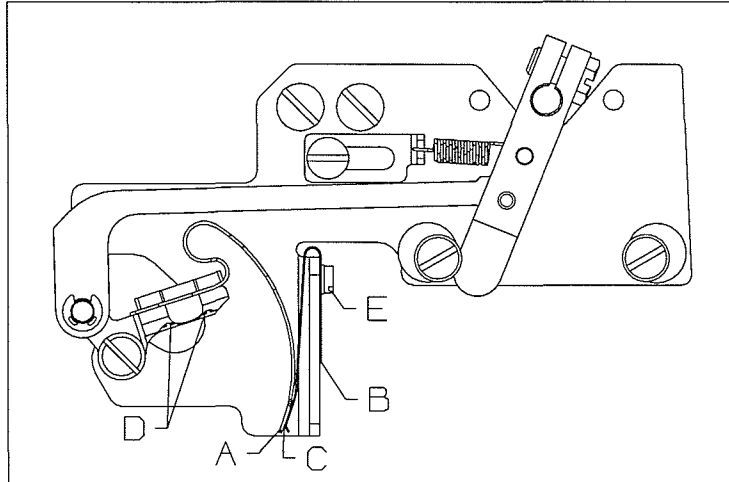

To lengthen travel past left needle.

Disconnect power supply to thread wiper.

Loosen stop screw (A) and rotate eccentric (B) so high lobe is further to left. Retighten stop screw (A).

To move wiper higher in leaf spring.

Loosen screw (C) and rotate eccentric (D) so high lobe is further to the right. Tighten stop screw (C).

Reconnect power supply.

NOTE: Recheck leaf spring setting to wiper.

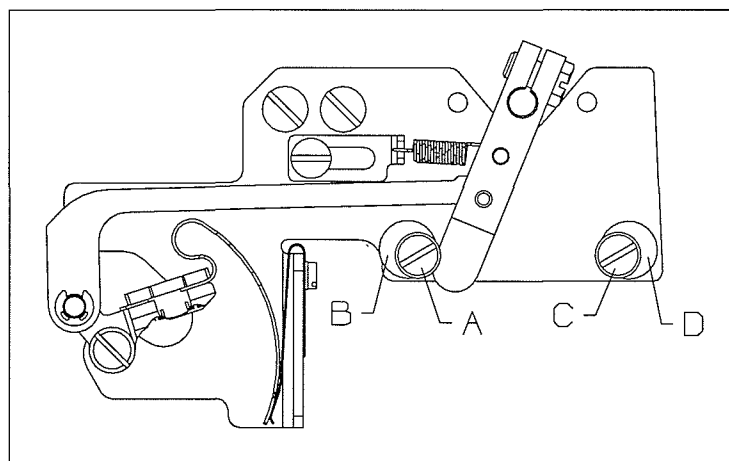

PNEUMATIC/ELECTRIC COVER THREAD TRIMMER

The following adjustments are made with the needles at top dead center.

Set the pressure of knife (A, Fig. 1) to the minimum and still cut the spreader thread.

The trimmer activates so the hook of the knife (A, Fig. 1) picks up the spreader thread from the underside where the thread goes from the spreader to the switch.

The bottom of the moving knife should be 2mm above the presser foot when the moving knife is extended, (Fig. 1).

The clearance of the knife tip (A, Fig. 1) should be .4 to .8mm from the left needle (B, Fig. 2) and .2 to .4mm from the spreader (C, Fig. 3). the angle should be set to pick up the spreader thread.

Tighten the set screw (D, Fig. 4) in the assembly holder and also tighten the set screw (E, Fig. 4) in the collar with the collar against the holder.

The collar screw should not be removed once the trimmer is adjusted. The collar will hold the adjusted position of the trimmer if it should be removed from the holder.

NOTE: Adjust the presser foot delay so it does not interfere with the trimmer.

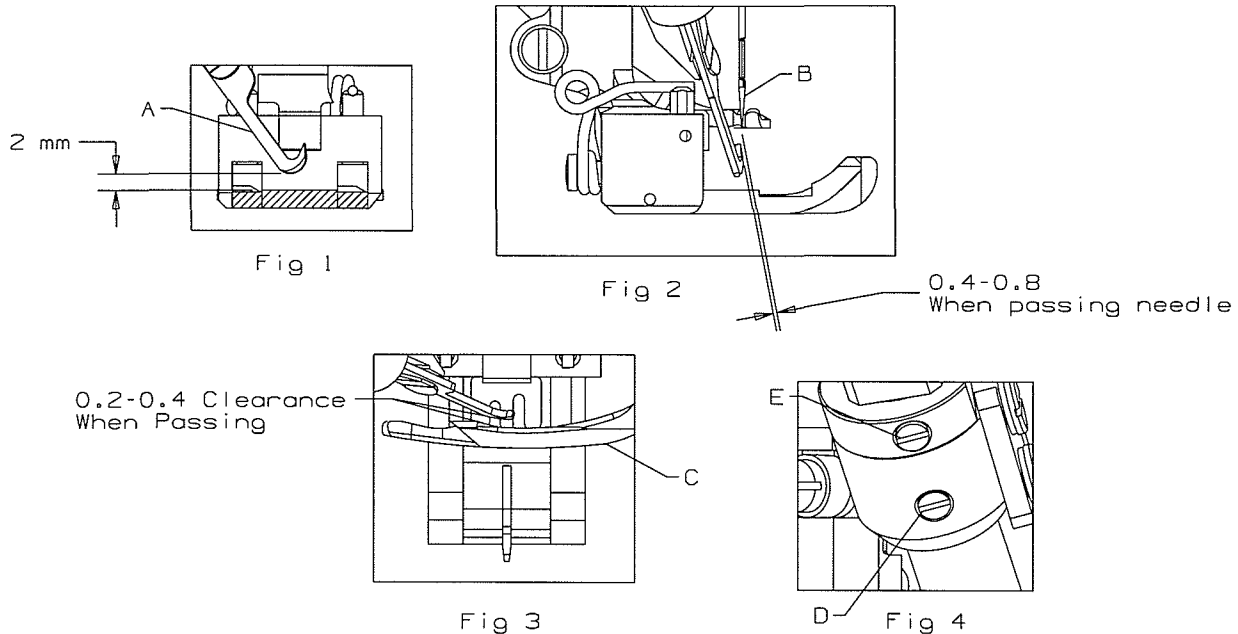

NEEDLE THREAD BLOWER ASSEMBLY

Needle threads must be blown out from under a raised presser foot after material has been removed.

AIR FLOW

1. Turn needle valve (A) clockwise to decrease air flow.
2. Turn needle valve (A) counterclockwise to increase air flow.

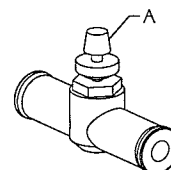
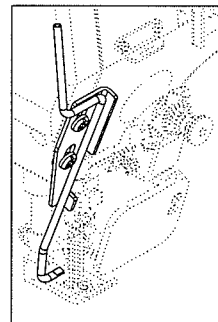

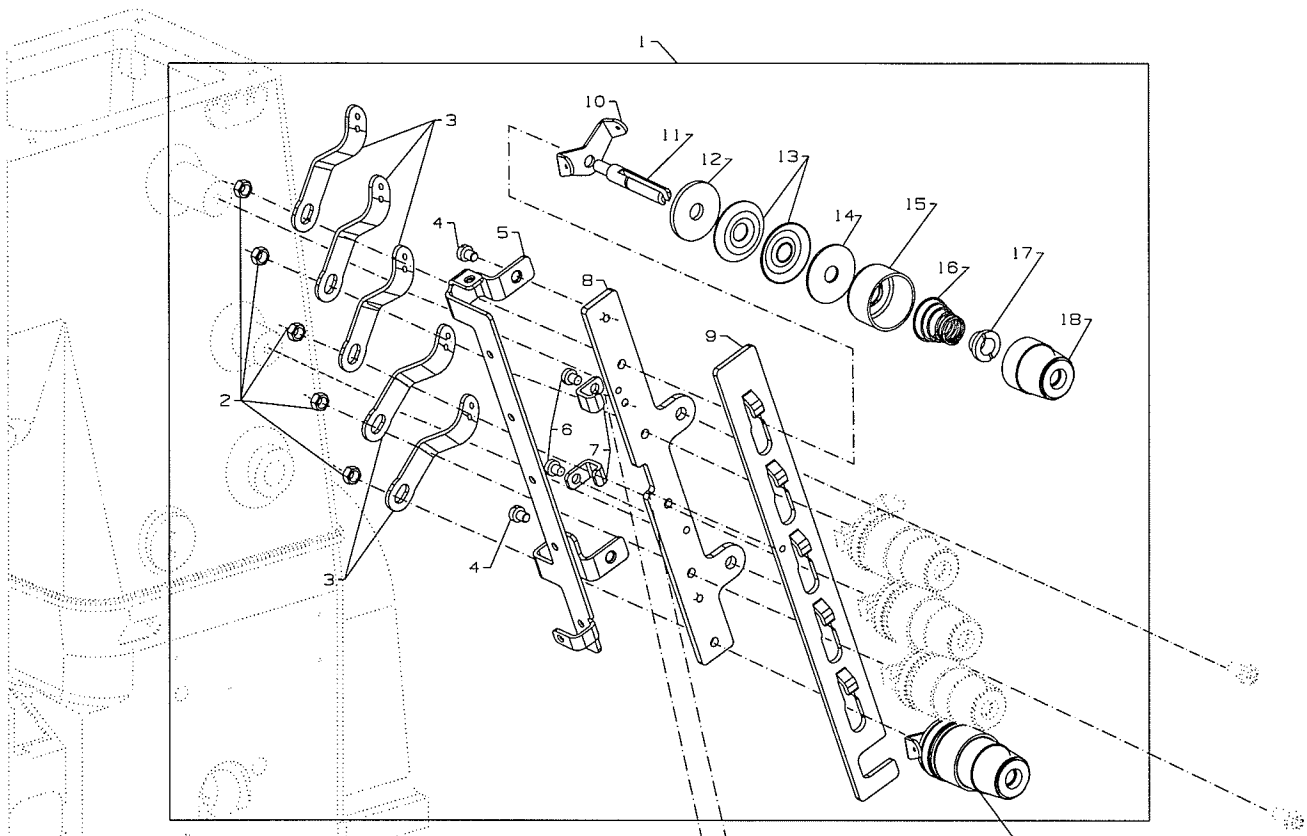

Note:
For Looper Tension
Details #12 And #14
Are Reversed

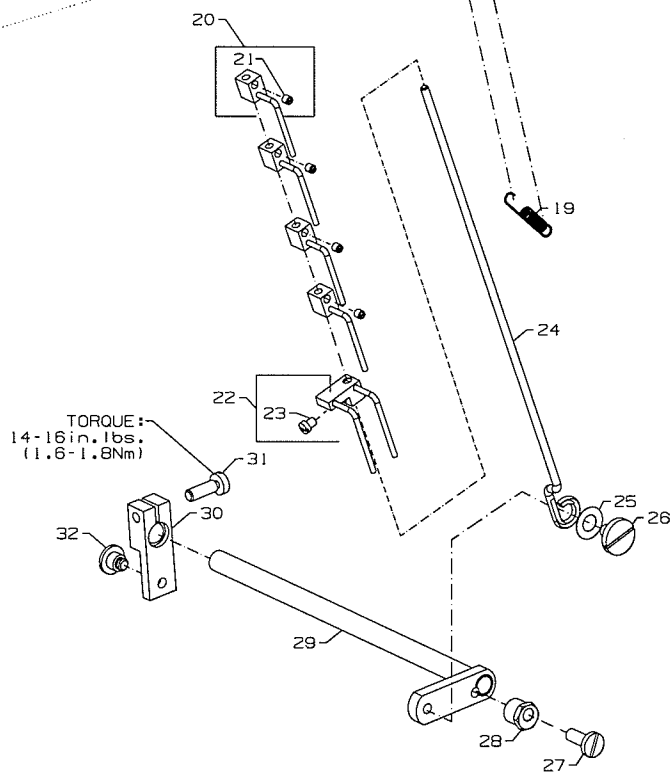

THREAD TENSION

Ref. No.	Part No.	Description	Amt. Req.
1.	29477NL	5 Thread Tension Assembly	1
2.	NS6110420SP	Nut	5
3.	57865	Lead-in Thread Guide	5
4.	SS7090520SP	Screw	2
5.	50392AP	Thread Guide	1
6.	SS7090520SP	Screw	2
7.	50392AV	Guide, for tension disc separator	2
8.	50392X	Tension Bracket	1
9.	50392AR	Tension Disc Separator	1
10.	57892K	Thread Tension Eyelet	5
11.	56392G	Tension Post	5
12.	666-330	Tension Disc Felt	5
13.	B3126012000	Tension Disc	10
14.	B3120352000	Tension Disc Felt	5
15.	56392H	Spring Shield	5
16.	B3103804000	Spring, for spreader (blue)	1
-	B3101804000	Spring, for needle (red)	3
-	B3121804000	Spring, for looper (plain)	1
17.	B3112704000	Ferrule, for tension spring	5
18.	56392M	Knob, for spreader (blue)	1
-	56392L	Knob, for needle (red)	3
-	50392R	Knob, for looper (plain)	1
19.	96711	Extension Spring	1
20.	50358Y	Thread Pull-off Hook	4
21.	28C	Screw	4
22.	A9858	Thread Pull-off Hook	1
23.	77A	Screw	1
24.	50392AS	Puller Rod, for thread puller	1
25.	50374A	Washer	1
26.	99296	Shoulder Screw	1
27.	22757	Screw	1
28.	G51346KA	Tension Release Eccentric	1
29.	50392AN	Tension Release Assembly	1
30.	99620	Tension Release Lever	1
31.	22596	Screw	1
32.	22735	Screw	1

UT COMPONENT DEVICE KEY	
UT DEVICE	COMPONENT USED ON DEVICE
UT1CS1	•
UT2CS1	•
UT3CS1	•
UT4CS1	•
UT5CS1	•



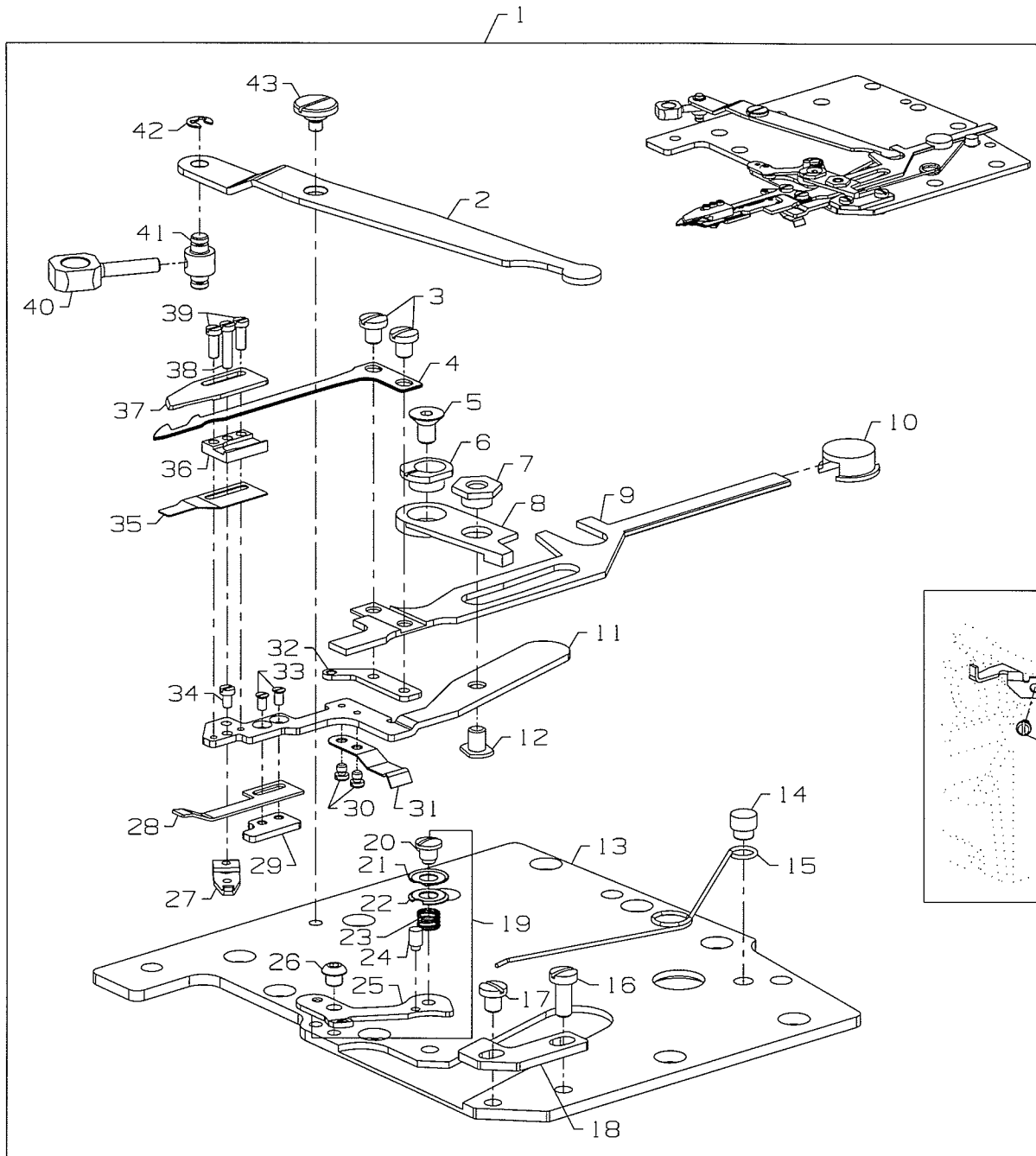

UNDERBED THREAD TRIMMER ASSEMBLY

Ref. No.	Part No.	Description	Amt. Req.
1.	29480AYH	Underbed Thread Trimmer Assembly	1
2.	34763P	Lever	1
3.	18-1453	Screw	2
4.	34749P	Lower Knife	1
5.	18-1450	Screw	1
6.	34768A	Eccentric Guide	1
7.	34768C	Guide Washer	1
8.	34750R	Lever	1
9.	34750T	Lower Knife Holder	1
10.	34750U	Guide	1
11.	34750SA	Upper Knife Holder	1
12.	18-1472	Screw	1
13.	34382AC	Oil Reserve Cover	1
14.	34751MS	Pin	1
15.	50332AD	Spring	1
16.	22585	Screw	1
17.	18-1449	Screw	2
18.	50337AX	Stop	1
19.	29480AYJ	Looper Thread Nipper Assembly	1
20.	50357AW	Nipper Plate Screw	1
21.	50357AX	Nipper Plate	1
22.	50357AT	Nipper Plate	1
23.	50357AU	Nipper Spring	1
24.	50357AV	Nipper Guard Post	1
25.	50366L	Nipper Plate Eyelet	1
26.	18C1471	Screw	1
27.	34751MT	Tension Lever	1
28.	34773D	Leaf Spring	1
29.	34769B	Threaded Plate	1
30.	SM6020250TP	Screw	2
31.	34773E	Leaf Spring	1
32.	50368AE	Looper Thread Pull-off Eyelet	1
33.	SM1020450TP	Screw	2
34.	18-1473	Screw	1
35.	34773F	Leaf Spring	1
36.	34750P	Lower Knife Guide	1
37.	34770M	Upper Knife	1
38.	18-1474	Screw	1
39.	SM6020600TP	Screw	2
40.	34752M	Driving Link	1
41.	34752N	Carrier Bolt	1
42.	RE025000KO	E-Ring	1
43.	SD0600176SP	Screw	1
44.	34794A	Guide	1
45.	90	Screw, for guide	2

UT COMPONENT DEVICE KEY	
UT DEVICE	COMPONENT USED ON DEVICE
UT1CS1	•
UT2CS1	•
UT3CS1	•
UT4CS1	•
UT5CS1	•



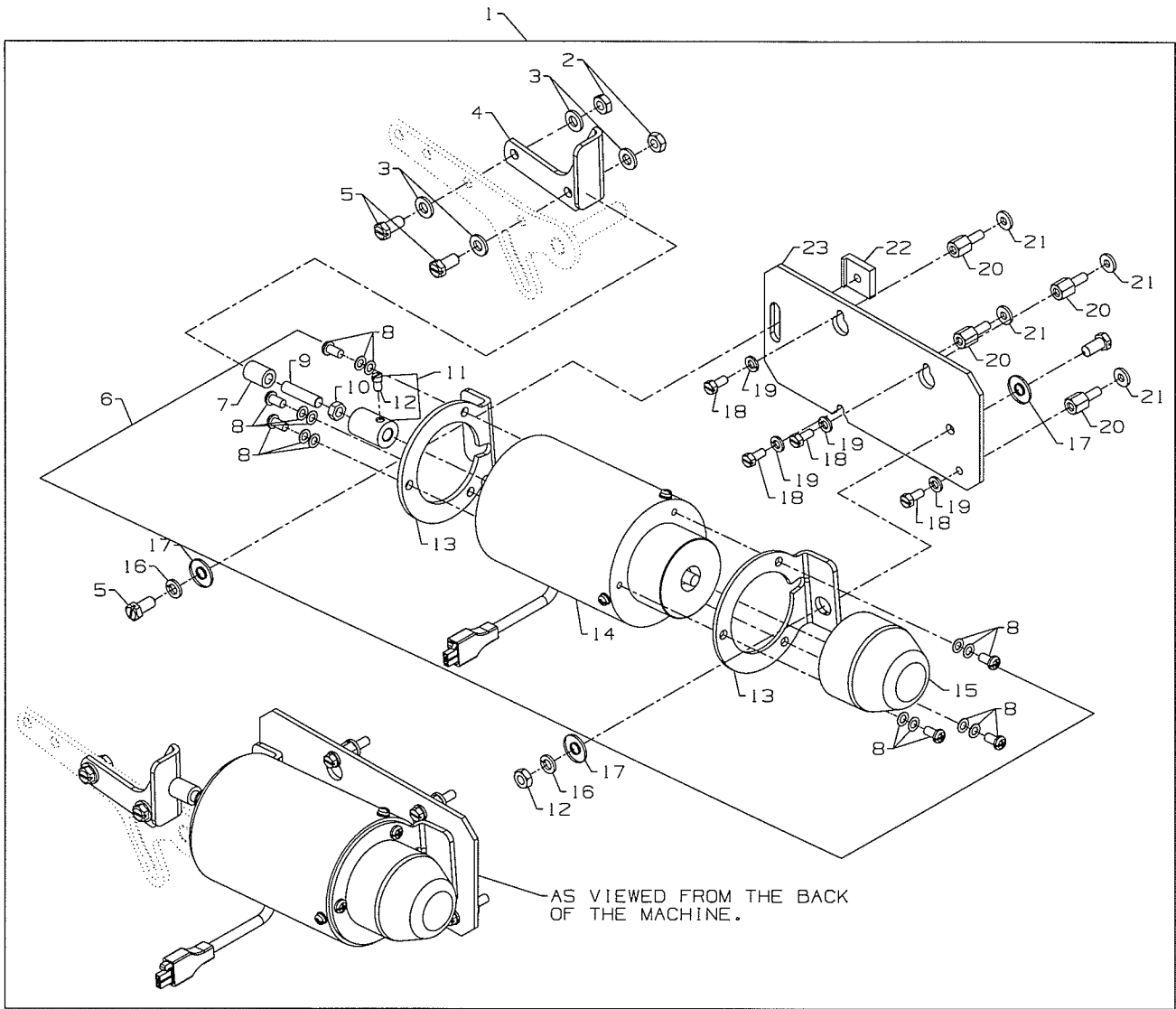

ELECTRIC PRESSER FOOT LIFTER ASSEMBLY

Ref. No.	Part No.	Description	Amt. Req.
1.	29921D	Electric Drive Assembly	1
2.	NS6150430SP	Nut	3
3.	95951	Washer	4
4.	50367H	Lifter	1
5.	SS9151420TP	Hex Screw	4
6.	670K29	Solenoid Assembly	1
7.	92855A	Cap	1
8.	SS4051281SE	Screw	6
9.	50395N	Stud	1
10.	NS6660430SP	Nut	1
11.	50333B	Coupling	1
12.	SS6110710TP	Screw	1
13.	GAK33034000	Bracket	2
14.	GAK8403000A	Solenoid	1
15.	GAK3303600A	Cap	1
16.	WS0631510KP	Lock Washer	2
17.	53636C	Washer	3
18.	SS9111010SP	Hex Screw	4
19.	WS0510002KP	Lock Washer	4
20.	50395P	Stand-Off	4
21.	35032H	Washer	4
22.	50395R	Clamp Plate	1
23.	50383S	Base Plate	1

UT COMPONENT DEVICE KEY	
UT DEVICE	COMPONENT USED ON DEVICE
UT1CS1	•
UT2CS1	•
UT3CS1	
UT4CS1	
UT5CS1	



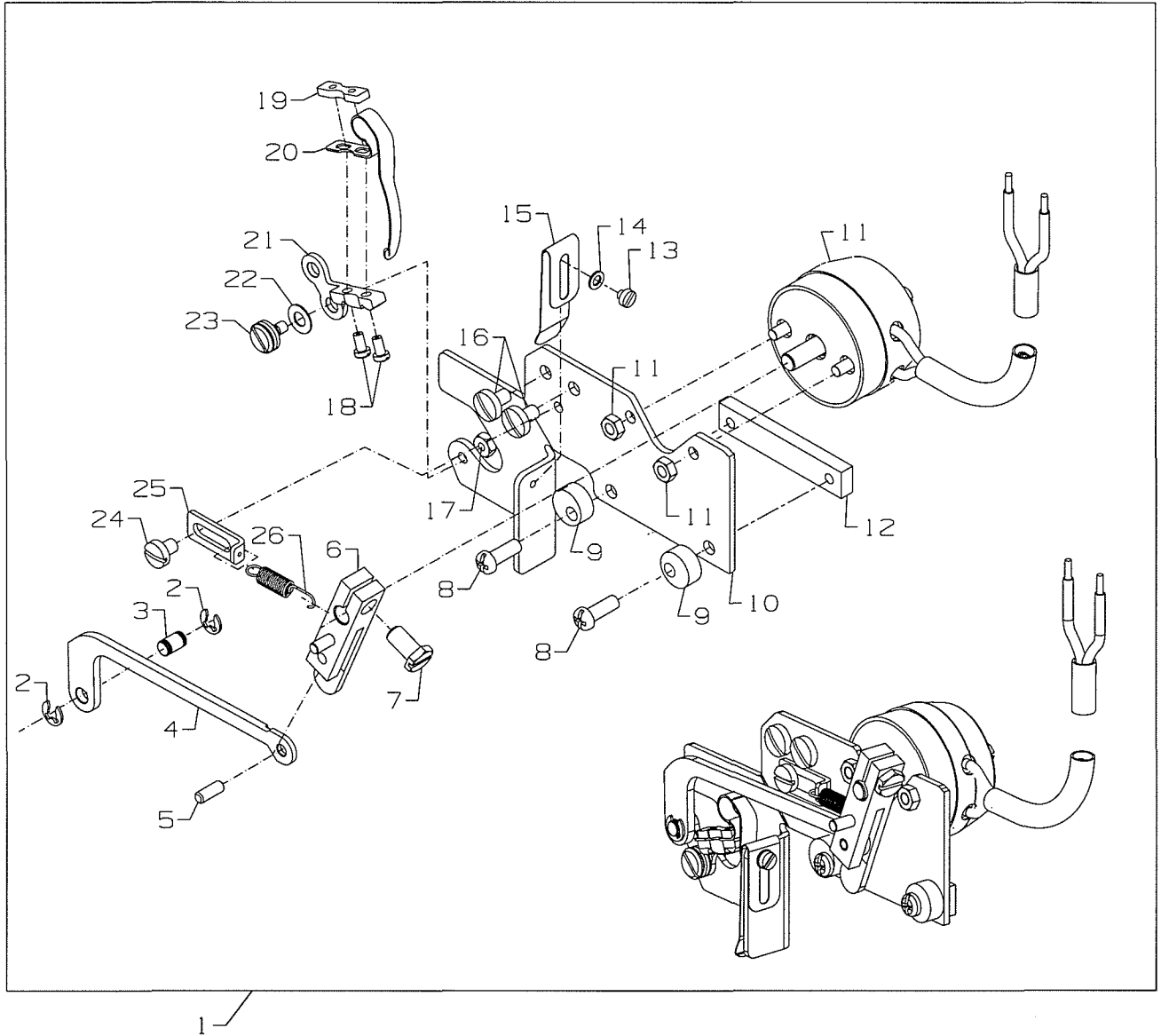

ELECTRIC THREAD WIPER ASSEMBLY

Ref. No.	Part No.	Description	Amt. Req.
1.	29906M	Electric Thread Drive Assembly	1
2.	96280	Retaining Ring	2
3.	99591DN	Pin	1
4.	99545G	Push Rod	1
5.	PH0300083U0	Pin	1
6.	99646J	Lever	1
7.	SS9120910TP	Screw	1
8.	SS4091015SP	Screw	2
9.	50363BF	Stop Eccentric	2
10.	99650E	Wiper Bracket	1
11.	670K15	Electric Solenoid Rotary	1
12.	99545H	Nut Plate	1
13.	SS6060210SP	Screw	1
14.	96150	Washer	1
15.	99697AA	Leaf Spring	1
16.	SS7090610SP	Screw	2
17.	51250C	Hex Nut	1
18.	SS6060510TP	Screw	2
19.	50362B	Plate	1
20.	99653B	Wiper Hook	1
21.	99657E	Lever	1
22.	96161	Washer	1
23.	99358	Shoulder Screw	1
24.	SS7090510SP	Screw	1
25.	99591DP	Bracket	1
26.	50332AB	Extension Spring	1

UT COMPONENT DEVICE KEY	
UT DEVICE	COMPONENT USED ON DEVICE
UT1CS1	•
UT2CS1	
UT3CS1	
UT4CS1	
UT5CS1	



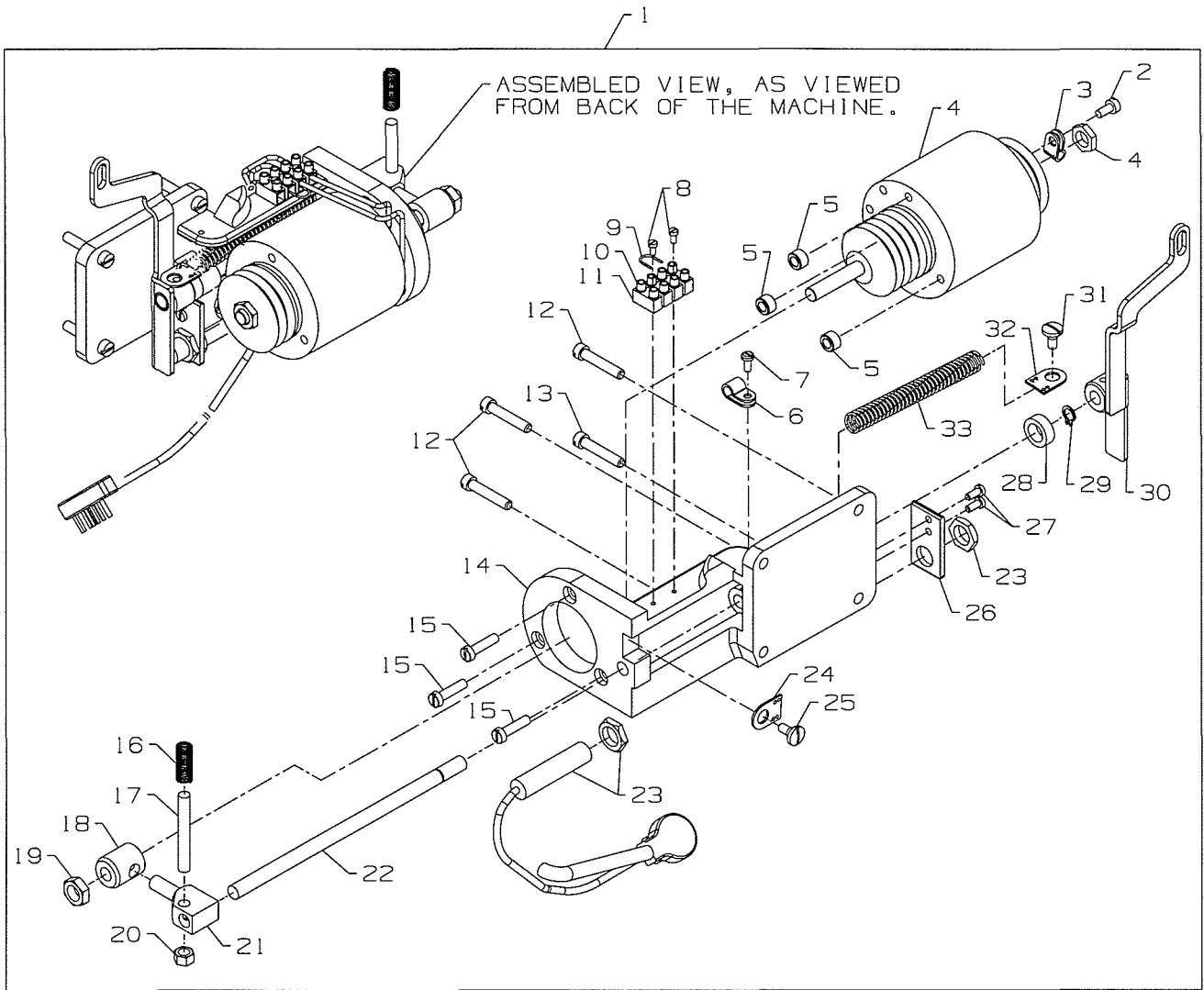

ELECTRIC DRIVE DOUBLE ACTION ASSEMBLY

Ref. No.	Part No.	Description	Amt. Req.
1.	670K28	Electric Drive Assembly	1
2.	95169	Screw	1
3.	670E1508	Cable Clamp	1
4.	998-306B	Solenoid	1
5.	99617A	Bushing	3
6.	998-358E	Hose Clamp	2
7.	SS611101OSP	Screw	1
8.	95179K	Screw	2
9.	1318001	Wire	1
10.	670E1302	Terminal Block	1
11.	998-297A	Cable End Plate	2
12.	22852A	Screw	3
13.	22517A	Screw	1
14.	G52882KW	Mounting Bracket	1
15.	95177	Screw	3
16.	51292F2	Spring	1
17.	99619	Clamping Screw	1
18.	99616	Driving Connection	1
19.	95251	Nut	1
20.	55235E	Nut	1
21.	99614D	Cross Head	1
22.	99613D	Shaft	1
23.	670E815	Switch Assembly	1
24.	80696RA	Spring Eyelet	1
25.	14076	Screw	1
26.	34762	Bracket	1
27.	22585	Screw	2
28.	99615	Washer	1
29.	96261	Retaining Ring	1
30.	50373DG	Lever	1
31.	22569B	Screw	1
32.	80696RA	Spring Eyelet	1
33.	96721	Spring	1

UT COMPONENT DEVICE KEY	
UT DEVICE	COMPONENT USED ON DEVICE
UT1CS1	•
UT2CS1	•
UT3CS1	
UT4CS1	
UT5CS1	



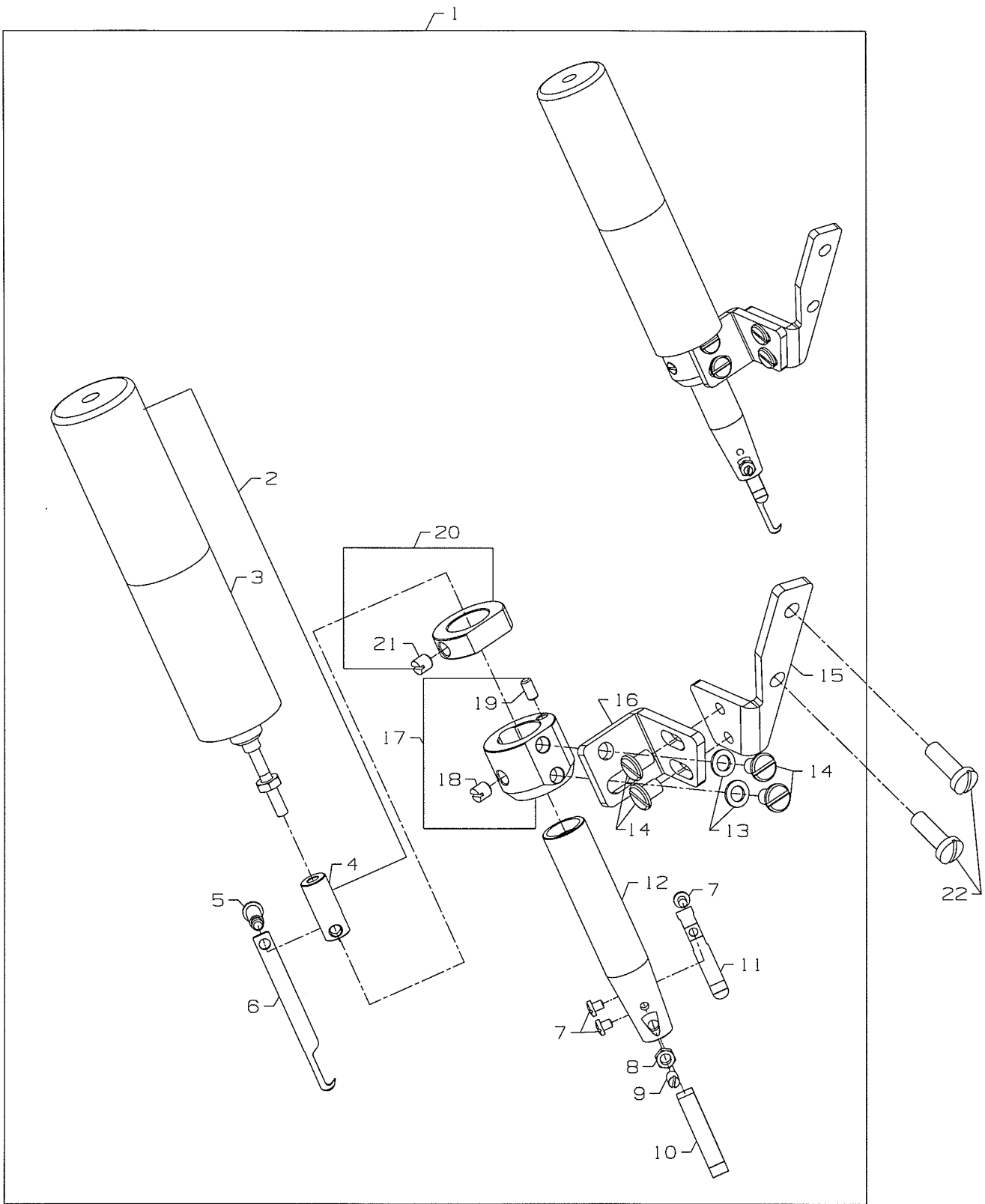

ELECTRIC SPREADER THREAD TRIMMER ASSEMBLY

Ref. No.	Part No.	Description	Amt. Req.
1.	29980LE	Spreader Thread Trimmer Assembly, Electric	1
2.	29105BR	Knife Holder Assembly	1
3.	670K85	Solenoid	1
4.	50372D	Moving Knife Holder	1
5.	22731	Screw	1
6.	50370H	Moving Knife	1
7.	SS706310SP	Screw	2
8.	NS6080210SP	Nut	1
9.	SS8080610SP	Screw	1
10.	50349F	Lower Knife	1
11.	50332AG	Spring	1
12.	50372C	Knife Holder	1
13.	WPO450846SP	Washer	2
14.	SS6110610TP	Screw	4
15.	50383AT	Bracket	1
16.	50383AS	Bracket	1
17.	50333L	Collar Guide	1
18.	SS8110520TP	Screw	1
19.	PH0300062C0	Pin	1
20.	50333K	Collar	1
21.	SS8110520TP	Screw	1
22.	SS4121915SP	Mounting Screws	2

UT COMPONENT DEVICE KEY	
UT DEVICE	COMPONENT USED ON DEVICE
UT1CS1	
UT2CS1	•
UT3CS1	
UT4CS1	
UT5CS1	



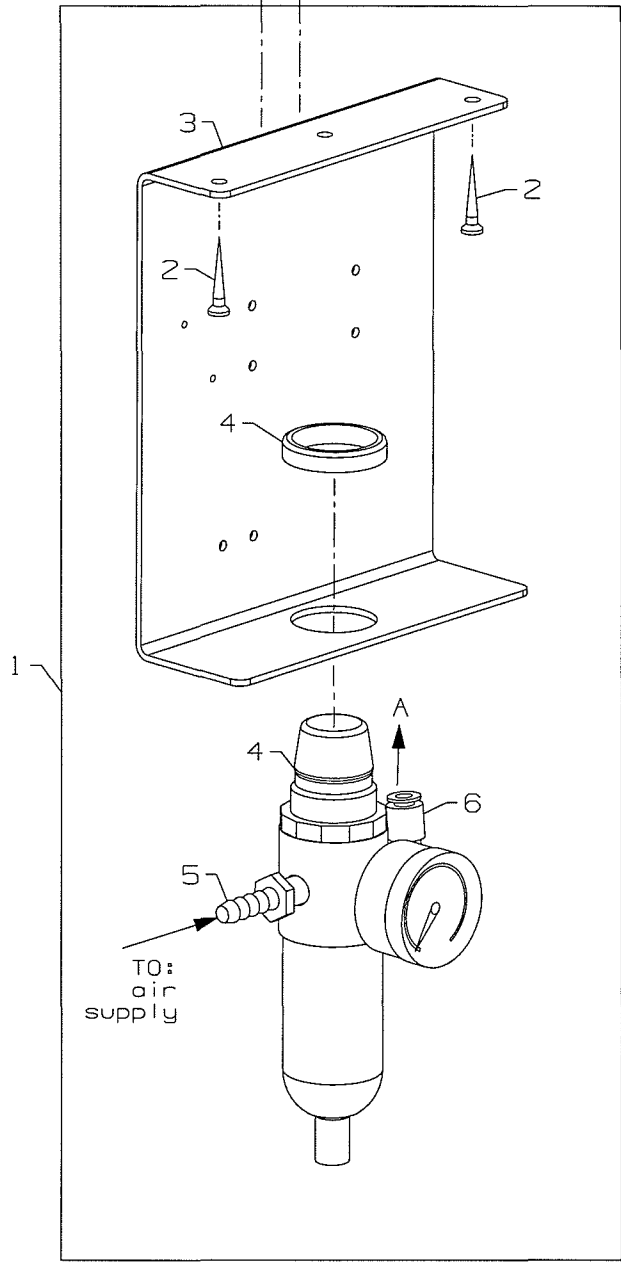
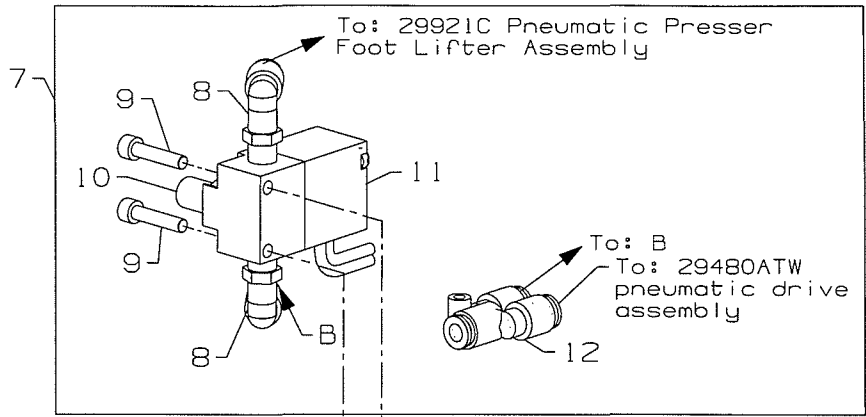

PNEUMATIC CONTROL

Ref. No.	Part No.	Description	Amt. Req.
1.	29480ASU	Pneumatic Control Kit	1
2.	90561K	Wood Screw	2
3.	99683CP	Mounting Bracket	1
4.	671D42	Filter/ Regulator Assembly	1
5.	671F88	Barb Fitting	1
6.	671F81A	Elbow Fitting - 6mm x 1/2" NPT	1
-	671B182	Air Tubing - 6mm O.D. x 1m (not shown)	1
7.	29480AST	Presser Foot Lifter Kit	1
8.	671F81C	Elbow Fitting - 6mm x 1/8" NPT	2
9.	95415	Screw - 4mm	2
10.	660-403	Muffler	1
11.	671-50	Valve	1
12.	671F86B	Splitter	1
-	670E673	Cable Harness (not shown)	1
-	RM2724A	Connector (male, not shown)	2
-	671B23	Air Tubing - 6mm O.D. x 1mm (not shown)	1

UT COMPONENT DEVICE KEY	
UT DEVICE	COMPONENT USED ON DEVICE
UT1CS1	
UT2CS1	
UT3CS1	•
UT4CS1	
UT5CS1	•



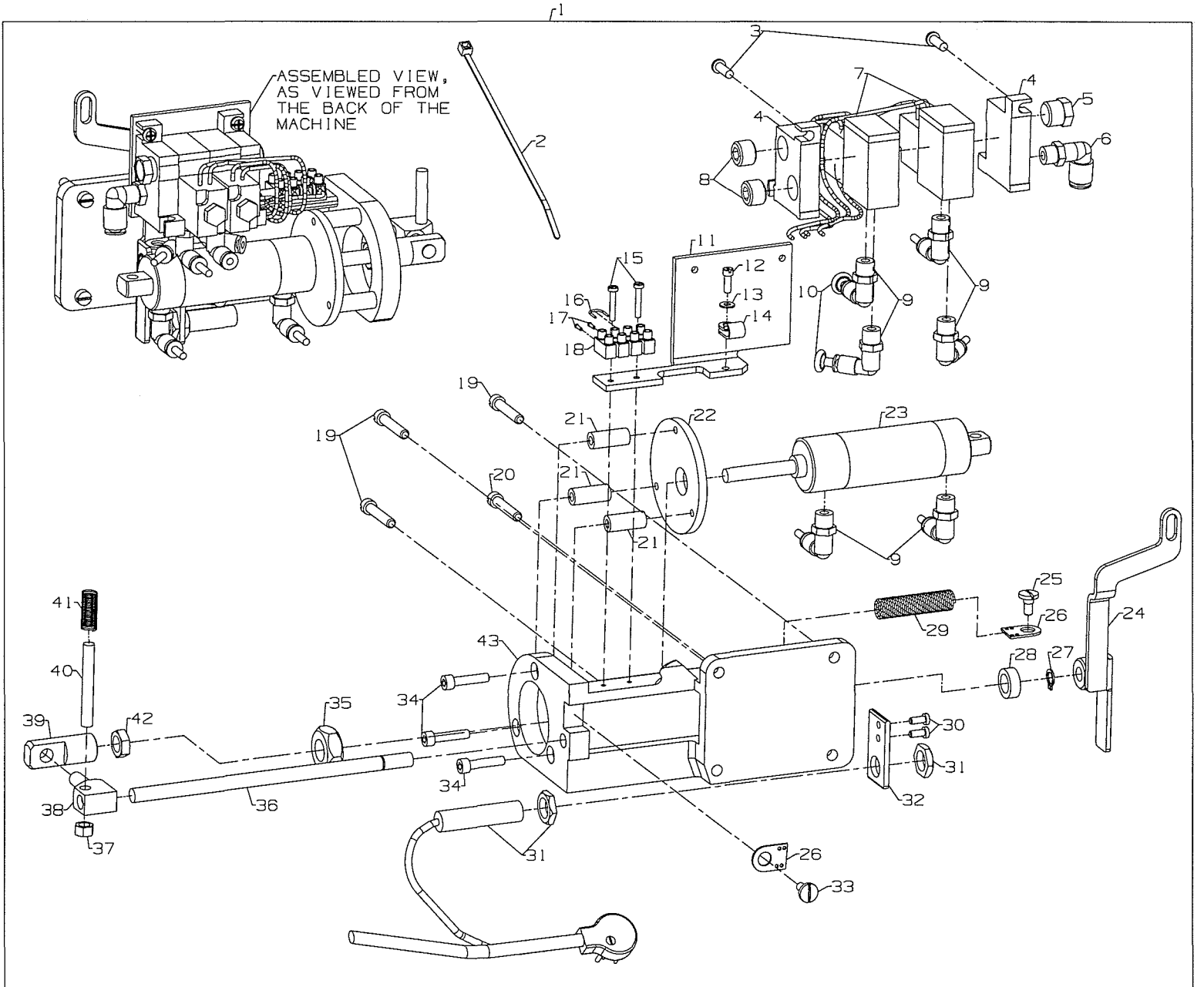

PNEUMATIC DRIVE DOUBLE ACTION ASSEMBLY

Ref. No.	Part No.	Description	Amt. Req.
1.	29480ATW	Pneumatic Drive Assembly	1
2.	RM2871B	Cable Tie	2
3.	SS4121415SP	Screw	2
4.	671-104A	Manifold	1
5.	660-763	Silencer	1
6.	671F81A	Elbow	1
7.	671-103B	Mac Valve	2
8.	671F87	Plug	2
9.	671F82C	Elbow	6
10.	670G276	Plug	2
11.	50383N	Bracket	1
12.	22729	Screw	1
13.	95954	Washer	1
14.	998-358E	Cable Clamp	1
15.	22894AX	Screw	2
16.	1318001	Wire	1
17.	998-297A	Cable End Sleeve	2
18.	670E1302	Terminal	1
19.	22852A	Screw	3
20.	22517A	Screw	1
21.	99617T	Spacer	3
22.	99591DH	Disc	1
23.	99694A	Air Cylinder	1
24.	50373DG	Lever	1
25.	22569B	Screw	1
26.	80696RA	Spring Eyelet	1
27.	96261	Retaining Ring	1
28.	99615	Washer	1
29.	96721	Spring	1
30.	22585	Screw	2
31.	670E815	Switch Assembly	1
32.	34762	Bracket	1
33.	14076	Stud	1
34.	95411	Screw	3
35.	99327	Nut	1
36.	99613D	Shaft	1
37.	55235E	Nut	1
38.	99614D	Cross Head	1
39.	99616A	Connector	1
40.	99619	Clamping	1
41.	51292F2	Spring	1
42.	21233FB	Nut	1
43.	G52882KW	Support Bracket	1
-	671B182	Tubing (not shown)	2ft.
-	6-878	Nylon Black Tubing (not shown)	1
-	998-358E	Hose Clamp (not shown)	1

UT COMPONENT DEVICE KEY	
UT DEVICE	COMPONENT USED ON DEVICE
UT1CS1	
UT2CS1	
UT3CS1	•
UT4CS1	•
UT5CS1	•



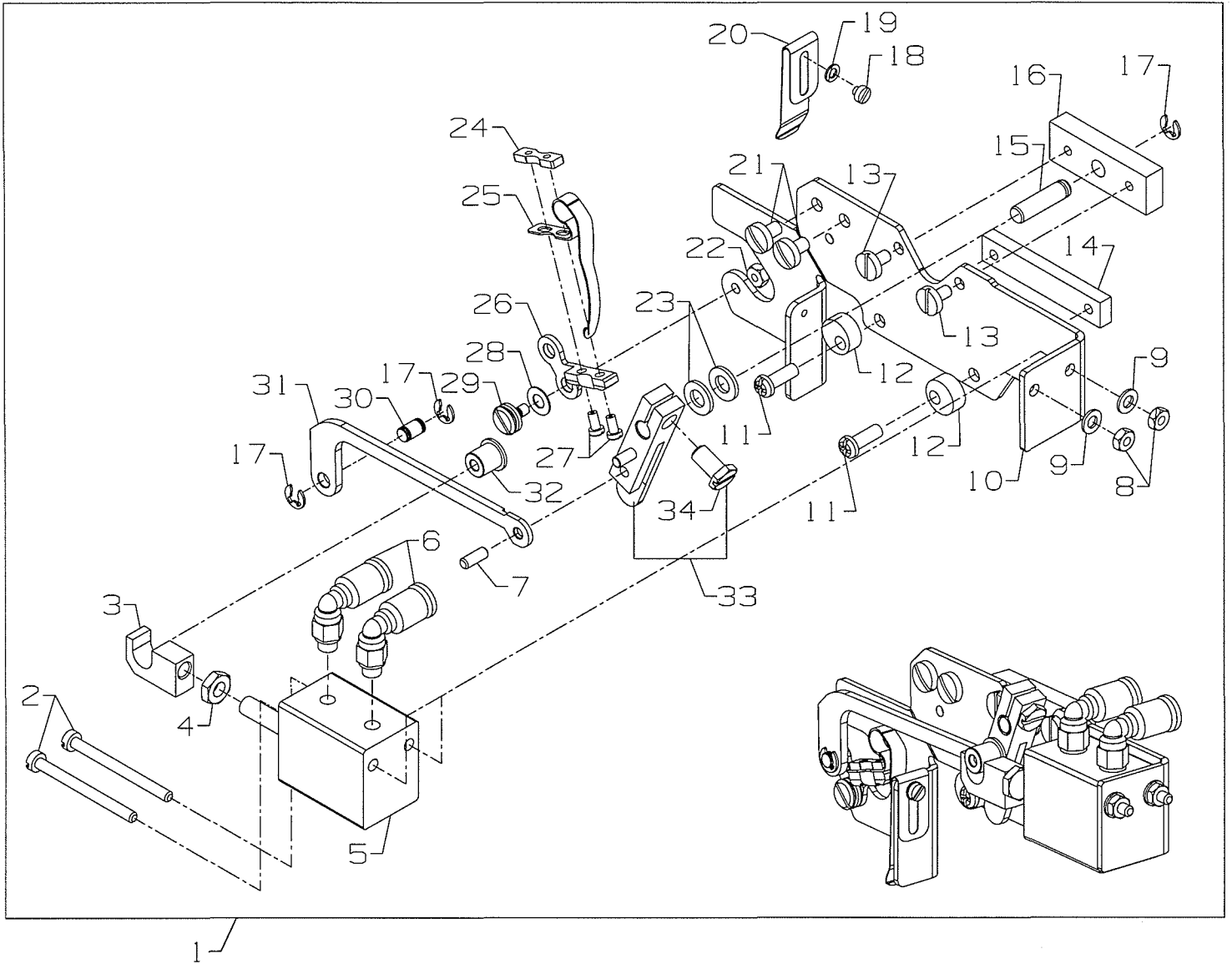

PNEUMATIC THREAD WIPER ASSEMBLY

Ref. No.	Part No.	Description	Amt. Req.
1.	29906L	Pneumatic Thread Wiper Assembly	1
2.	95167CV	Screw	2
3.	35086BK	Clevis	1
4.	95294	Hex Nut	1
5.	999-191H	Pneumatic Cylinder	1
6.	999-411M5-4	Pneumatic Fitting	2
7.	PH0300083UO	Pin	1
8.	95259	Hex Nut	2
9.	95956	Washer	2
10.	99650D	Wiper Bracket	1
11.	SS4091015SP	Screw	2
12.	50363BF	Stop Eccentric	2
13.	SS6080610TP	Screw	2
14.	99545H	Nut Plate	1
15.	52336B	Pin	1
16.	99545F	Plate	1
17.	96280	Retaining Ring	3
18.	SS6060210SP	Screw	1
19.	96150	Washer	1
20.	99697AA	Leaf Spring	1
21.	SS7090610SP	Screw	2
22.	51250C	Hex Nut	1
23.	99652A	Washer	2
24.	50362B	Plate	1
25.	99653B	Wiper Hook	1
26.	99657E	Lever	1
27.	SS6060510TP	Screw	2
28.	96161	Washer	1
29.	99358	Shoulder Screw	1
30.	99591DN	Pin	1
31.	99545G	Push Rod	1
32.	35086BJ	Roller	1
33.	99646J	Lever	1
34.	SS9120910TP	Screw	1

UT COMPONENT DEVICE KEY	
UT DEVICE	COMPONENT USED ON DEVICE
UT1CS1	
UT2CS1	
UT3CS1	•
UT4CS1	
UT5CS1	



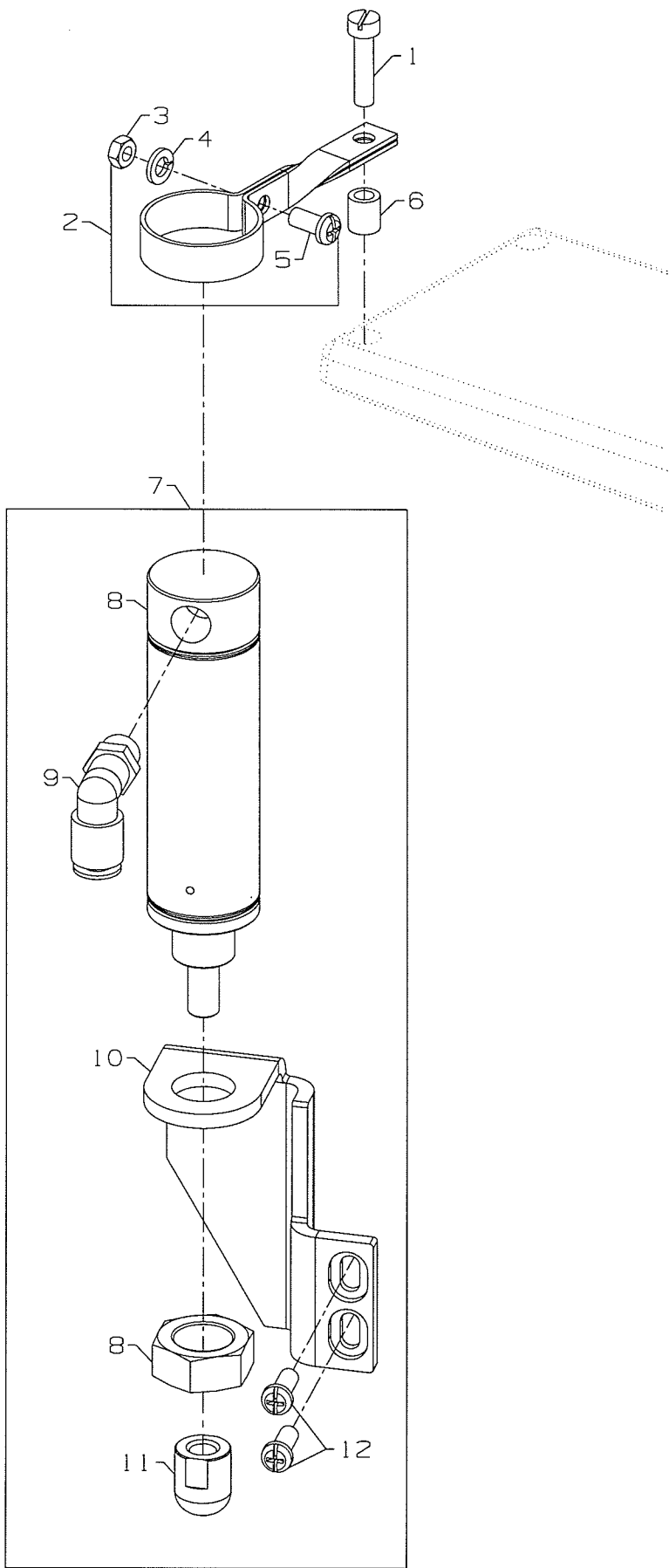

PRESSER FOOT LIFTER

Ref. No.	Part No.	Description	Amt. Req.
1.	SS6122030SP	Screw	1
2.	50383AR	Cylinder Support Bracket	1
3.	NS6120310SP	Nut	1
4.	WS0510002KP	Washer	1
5.	SS4121015SP	Screw	1
6.	50374K	Spacer	1
7.	29480AXJ	Presser Foot Lifter Assembly	1
8.	671A360	Air Cylinder	1
9.	671F81C	Fitting	1
10.	50383AF	Bracket	1
11.	660-1099	Air Cylinder Cap	1
12.	SS4121215SP	Screw	2

<i>UT COMPONENT DEVICE KEY</i>	
UT DEVICE	COMPONENT USED ON DEVICE
UT1CS1	
UT2CS1	
UT3CS1	•
UT4CS1	•
UT5CS1	•



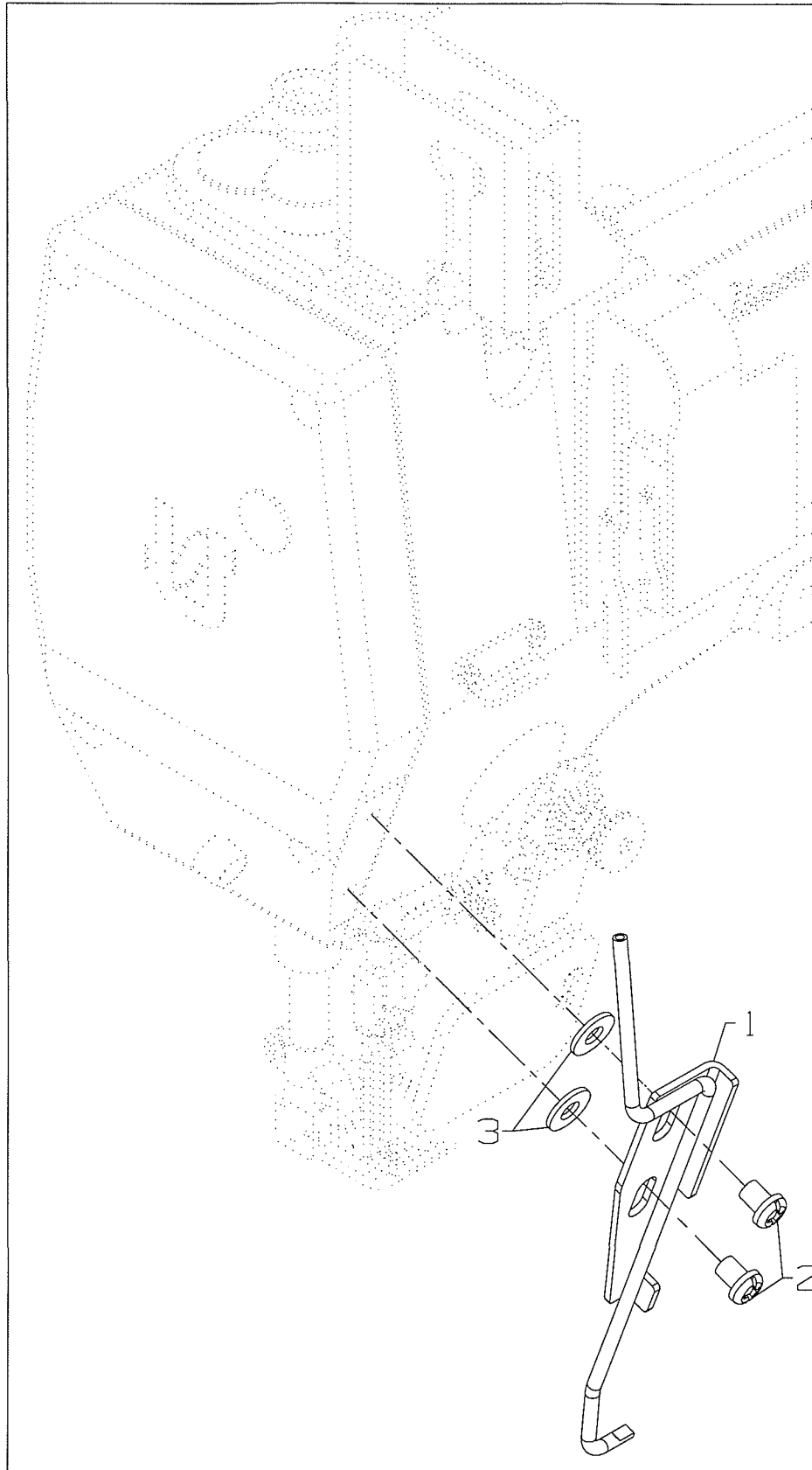

NEEDLE THREAD BLOWER ASSEMBLY

Ref. No.	Part No.	Description	Amt. Req.
1.	50394AJ	Needle Thread Blower Assembly	1
2.	SS4120615SP	Screw, for needle thread blower assembly	2
3.	69H	Washer	2

<i>UT COMPONENT DEVICE KEY</i>	
UT DEVICE	COMPONENT USED ON DEVICE
UT1CS1	
UT2CS1	
UT3CS1	
UT4CS1	•
UT5CS1	



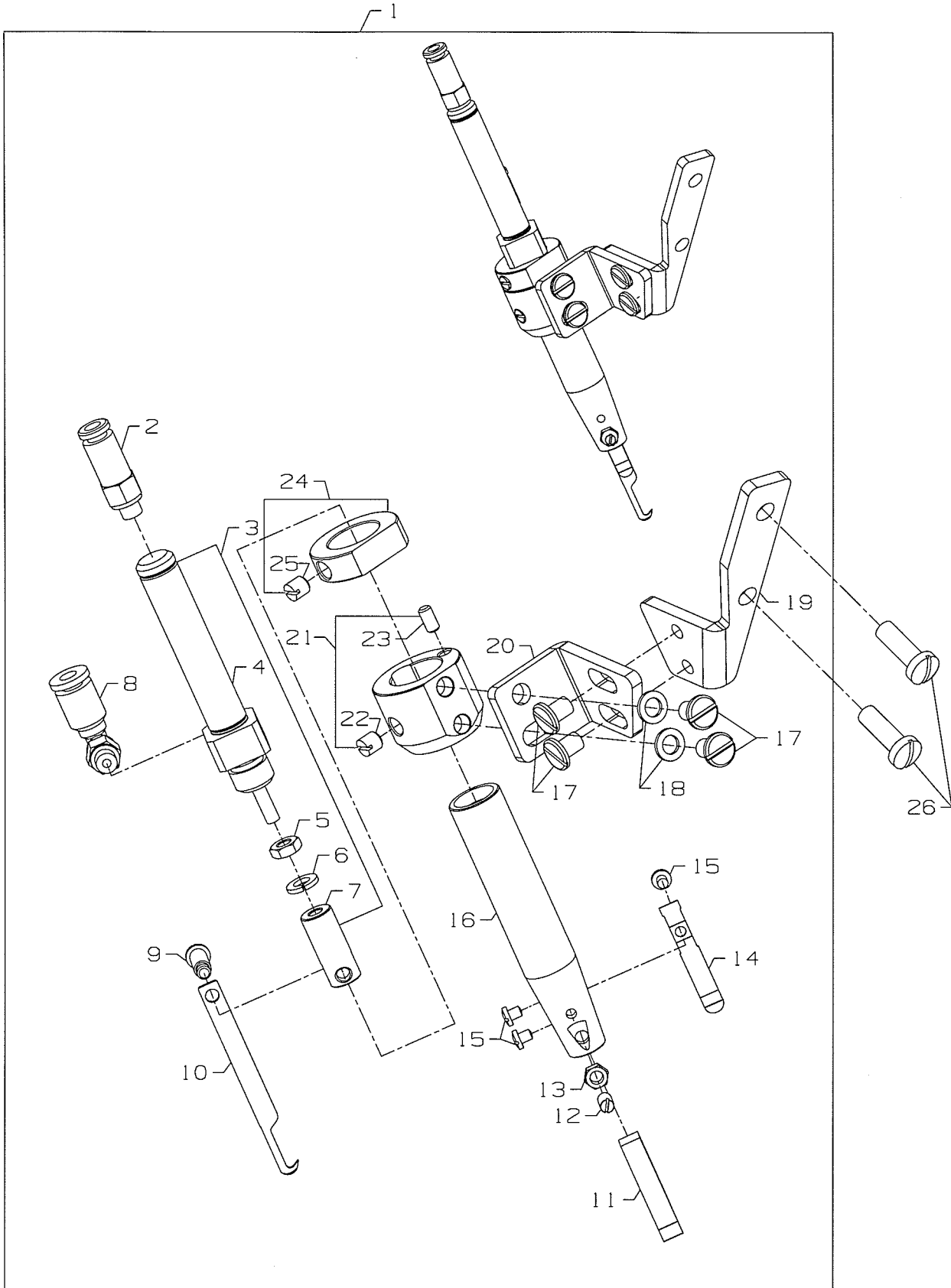

PNEUMATIC SPREADER THREAD TRIMMER ASSEMBLY

Ref. No.	Part No.	Description	Amt. Req.
1.	29980LD	Pneumatic Spreader Thread Trimmer Assembly	1
2.	671F82G	Male Connector	1
3.	29105BP	Knife Holder Assmebly	1
4.	671A363	Air Cylinder	1
5.	660-1105	Nut	1
6.	WS0410002KP	Washer	1
7.	50372D	Moving Knife Holder	1
8.	671F82F	Male Elbow	1
9.	22731	Screw	1
10.	50370H	Moving Knife	1
11.	50349F	Lower Knife	1
12.	SS8080610SP	Screw	1
13.	NS6080210SP	Nut	1
14.	50332AG	Spring	1
15.	SS7060310SP	Screw	3
16.	50372C	Knife Holder	1
17.	SS6110610TP	Screw	4
18.	WP0450846SP	Washer	2
19.	50383AT	Bracket	1
20.	50383AS	Bracket	1
21.	50333L	Collagr, guide	1
22.	SS8110520TP	Screw	1
23.	PH0300062C0	Pin	1
24.	50333K	Collar	1
25.	SS8110520TP	Screw	1
26.	SS4120915SP	Mounting Screws	2

UT COMPONENT DEVICE KEY	
UT DEVICE	COMPONENT USED ON DEVICE
UT1CS1	
UT2CS1	
UT3CS1	
UT4CS1	
UT5CS1	•



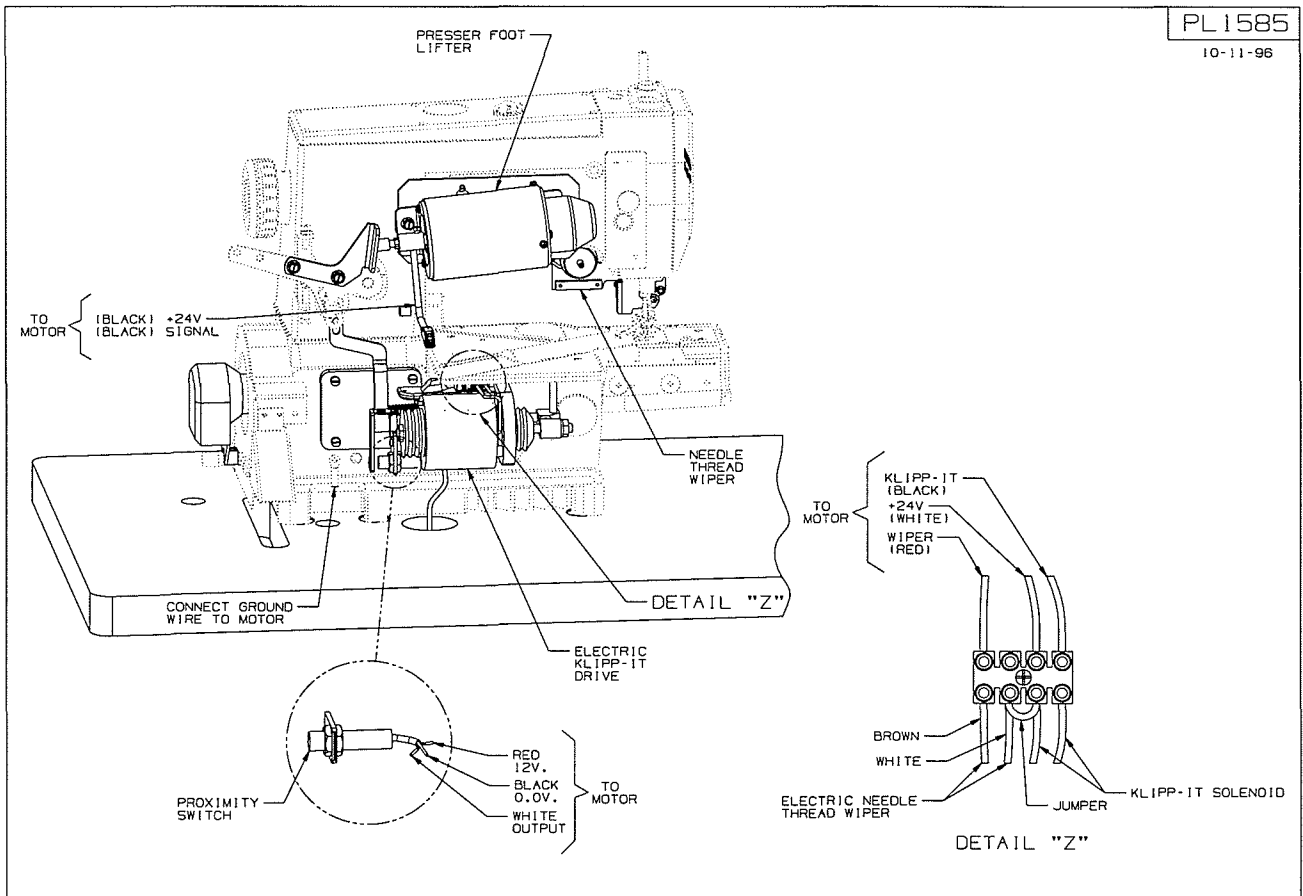

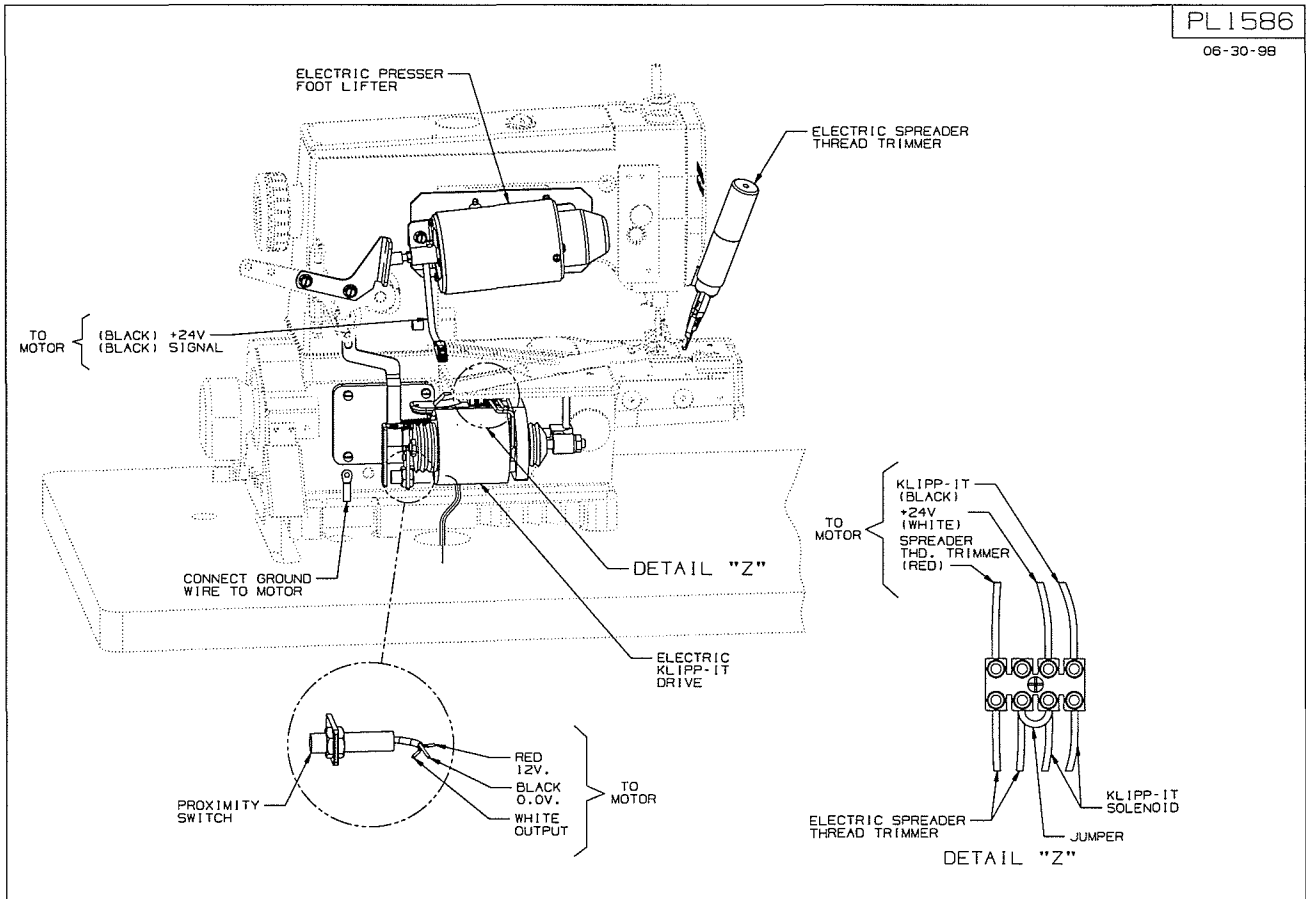

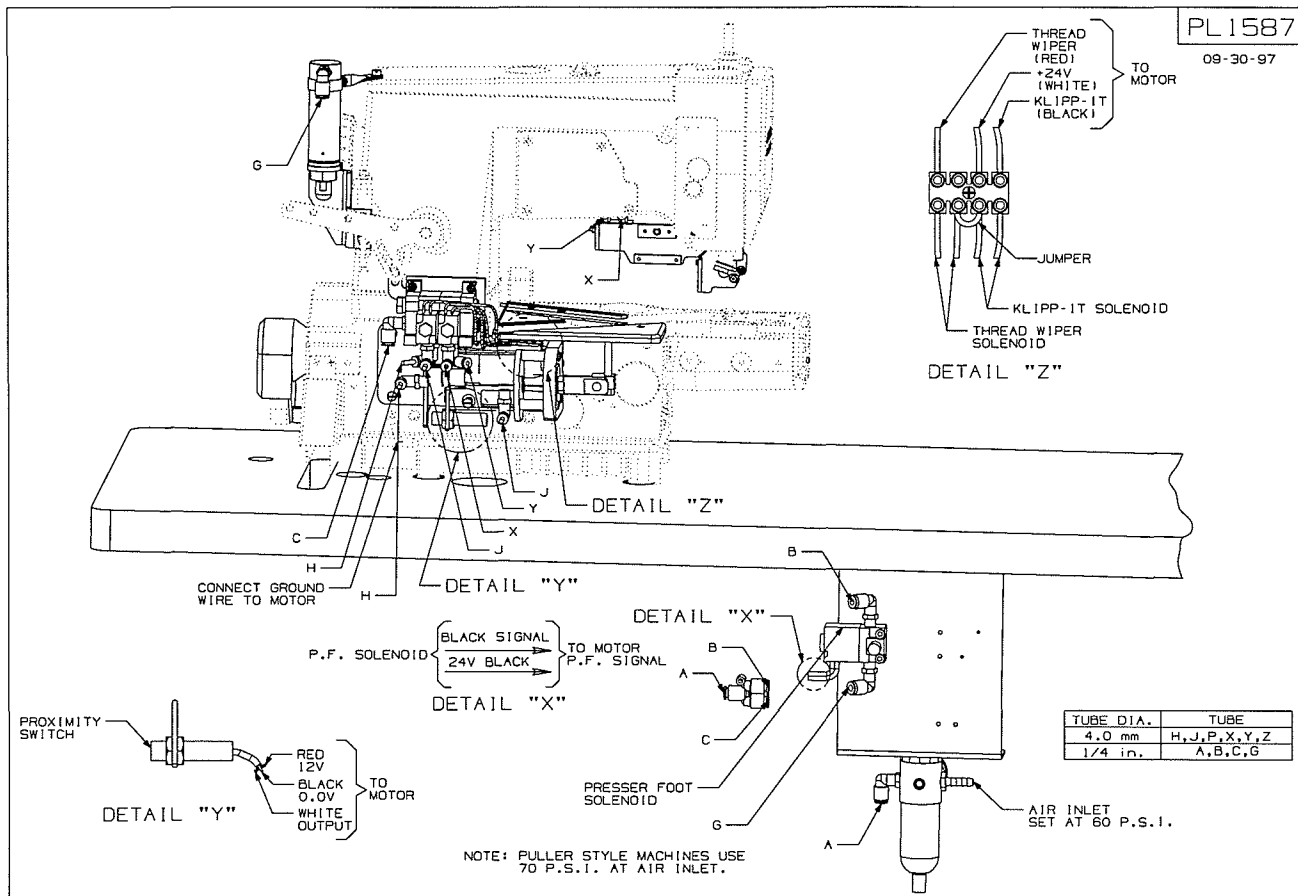

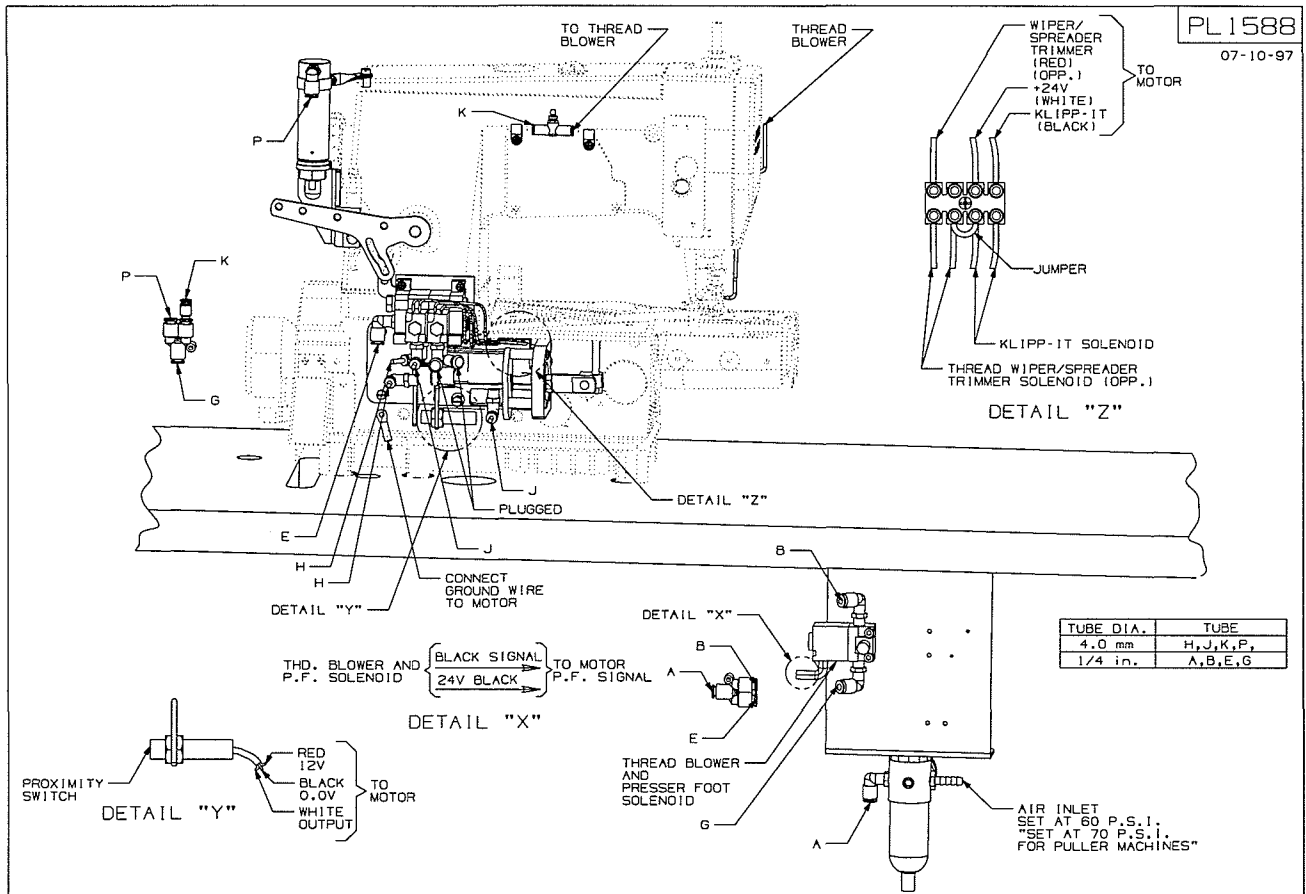

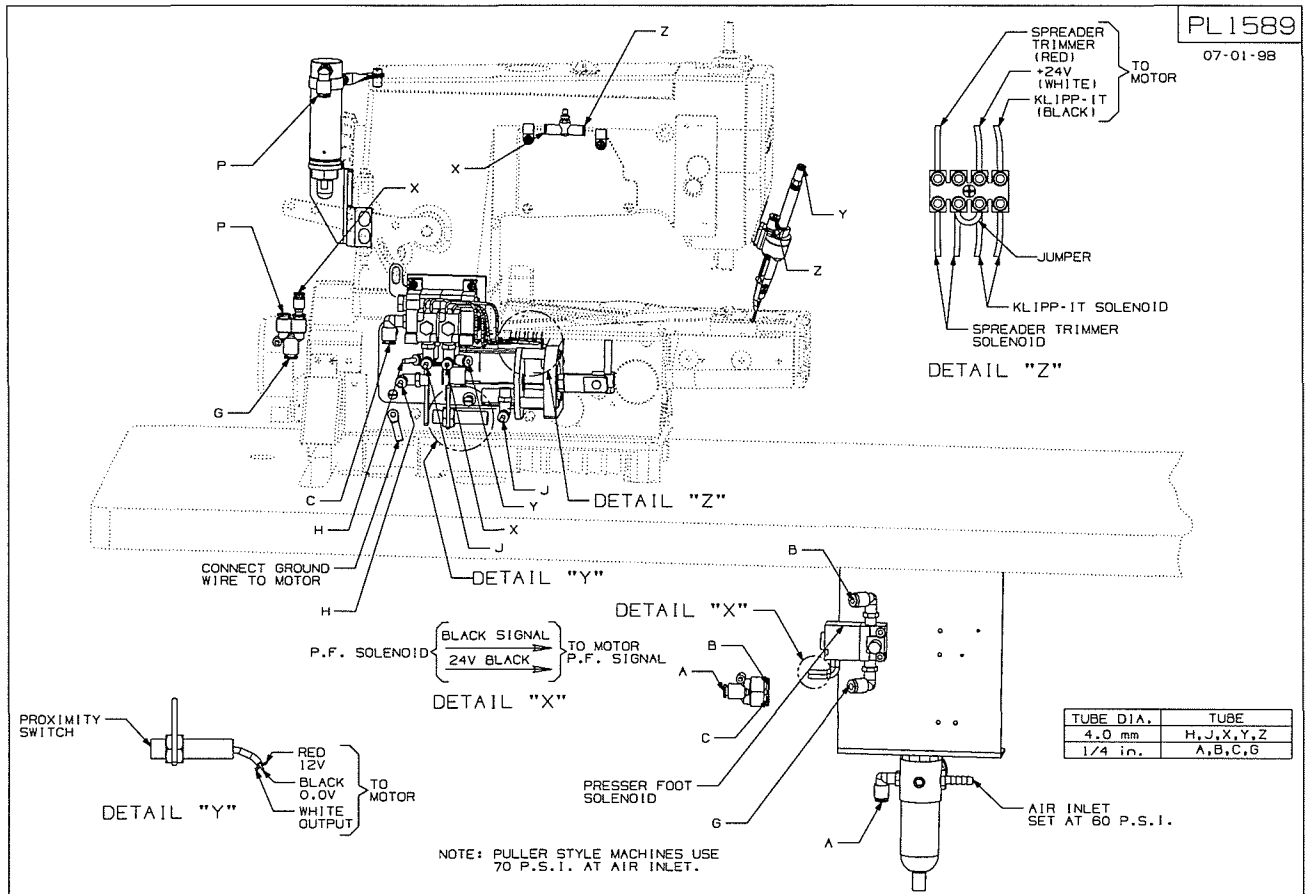

NUMERICAL INDEX OF PARTS

<u>Part No.</u>	<u>Page No.</u>	<u>Part No.</u>	<u>Page No.</u>	<u>Part No.</u>	<u>Page No.</u>	<u>Part No.</u>	<u>Page No.</u>
1318001 ...	27, 33	3 4 7 7 3 D ...	2 1	5 2 3 3 6 B ...	3 5	9 5 2 5 1 ...	2 7
14076 ...	27, 33	3 4 7 7 3 E ...	2 1	5 3 6 3 6 C ...	2 3	9 5 2 5 9 ...	3 5
18-1449 ...	2 1	3 4 7 7 3 F ...	2 1	55235E ...	27, 33	9 5 2 9 4 ...	3 5
18-1450 ...	2 1	3 4 7 9 4 A ...	2 1	5 6 3 9 2 G ...	1 9	9 5 4 1 1 ...	3 3
18-1453 ...	2 1	3 5 0 3 2 H ...	2 3	5 6 3 9 2 H ...	1 9	9 5 4 1 5 ...	3 1
18-1472 ...	2 1	3 5 0 8 6 B J ...	3 5	5 6 3 9 2 L ...	1 9	9 5 9 5 1 ...	2 3
18-1473 ...	2 1	3 5 0 8 6 B K ...	3 5	5 6 3 9 2 M ...	1 9	9 5 9 5 4 ...	3 3
18-1474 ...	2 1	5 0 3 3 2 A B ...	2 5	5 7 8 6 5 ...	1 9	9 5 9 5 6 ...	3 5
18C1471 ...	2 1	5 0 3 3 2 A D ...	2 1	5 7 8 9 2 K ...	1 9	96150 ...	25, 35
21233FB ...	3 3	50332AG ...	29, 41	6 - 8 7 8 ...	3 3	96161 ...	25, 35
22517A ...	27, 33	5 0 3 3 3 B ...	2 3	660-1099 ...	3 7	96261 ...	27, 33
22569B ...	27, 33	50333K ...	29, 41	660-1105 ...	4 1	96280 ...	25, 35
22585 ...	21, 27, 33	50333L ...	29, 41	660-403 ...	3 1	9 6 7 1 1 ...	1 9
2 2 5 9 6 ...	1 9	50337AX ...	2 1	660-763 ...	3 3	96721 ...	27, 33
2 2 7 2 9 ...	3 3	50349F ...	29, 41	666-330 ...	1 9	9 9 2 9 6 ...	1 9
22731 ...	29, 41	50357AT ...	2 1	670E1302 ...	27, 33	9 9 3 2 7 ...	3 3
2 2 7 3 5 ...	1 9	50357AU ...	2 1	670E1508 ...	2 7	9 9 3 5 8 ...	2 5
2 2 7 5 7 ...	1 9	50357AV ...	2 1	670E673 ...	3 1	9 9 5 4 5 F ...	3 5
22852A ...	27, 33	50357AW ...	2 1	670E815 ...	27, 33	99545G ...	25, 35
22894AX ...	3 3	50357AX ...	2 1	670G276 ...	3 3	99545H ...	25, 35
2 8 C ...	1 9	5 0 3 5 8 Y ...	1 9	670K15 ...	2 5	99591DH ...	3 3
29105BP ...	4 1	50362B ...	25, 35	670K28 ...	2 7	99591DN ...	25, 35
29105BR ...	2 9	50363BF ...	25, 35	670K29 ...	2 3	99591DP ...	2 5
29477NL ...	1 9	5 0 3 6 6 L ...	2 1	670K85 ...	2 9	99613D ...	27, 33
29480AST ...	3 1	5 0 3 6 7 H ...	2 3	671-103B ...	3 3	99614D ...	27, 33
29480ASU ...	3 1	50368AE ...	2 1	671-104A ...	3 3	99615 ...	27, 33
29480ATW ...	3 3	50370H ...	29, 41	671-50 ...	3 1	9 9 6 1 6 ...	2 7
29480AXJ ...	3 7	50372C ...	29, 41	671A360 ...	3 7	9 9 6 1 6 A ...	3 3
29480AYH ...	2 1	50372D ...	29, 41	671A363 ...	4 1	9 9 6 1 7 A ...	2 7
29480AYJ ...	2 1	50373DG ...	27, 33	671B182 ...	31, 33	9 9 6 1 7 T ...	3 3
29906L ...	3 5	5 0 3 7 4 A ...	1 9	671B23 ...	3 1	99619 ...	27, 33
29906M ...	2 5	5 0 3 7 4 K ...	3 7	671B81C ...	3 1	9 9 6 2 0 ...	1 9
29921D ...	2 3	50383AF ...	3 7	671D42 ...	3 1	99646J ...	25, 35
29980LD ...	4 1	50383AR ...	3 7	671F81A ...	31, 33	9 9 6 5 0 E ...	2 5
29980LE ...	2 9	50383AS ...	29, 41	671F81C ...	3 7	9 9 6 5 2 A ...	3 5
34382AC ...	2 1	50383AT ...	29, 41	671F82C ...	3 3	99653B ...	25, 35
34749P ...	2 1	5 0 3 8 3 N ...	3 3	671F82F ...	4 1	99657E ...	25, 35
34750P ...	2 1	5 0 3 8 3 S ...	2 3	671F82G ...	4 1	99683CP ...	3 1
34750R ...	2 1	50392AN ...	1 9	671F86B ...	3 1	9 9 6 9 4 A ...	3 3
34750SA ...	2 1	50392AP ...	1 9	671F87 ...	3 3	99697AA ...	25, 35
34750T ...	2 1	50392AR ...	1 9	671F88 ...	3 1	998-297A ...	27, 33
34750U ...	2 1	50392AS ...	1 9	6 9 H ...	3 9	998-306B ...	2 7
34751MS ...	2 1	50392AV ...	1 9	7 7 A ...	1 9	998-358E ...	27, 33
34751MT ...	2 1	5 0 3 9 2 R ...	1 9	80696RA ...	27, 33	999-191H ...	3 5
34752M ...	2 1	5 0 3 9 2 X ...	1 9	9 0 ...	2 1	999-411-M5-4 ...	3 5
34762 ...	27, 33	50394AJ ...	3 9	9 0 5 6 1 K ...	3 1	A 9 8 5 8 ...	1 9
34763P ...	2 1	5 0 3 9 5 N ...	2 3	9 2 8 5 5 A ...	2 3	B3101804000 ...	1 9
34768A ...	2 1	5 0 3 9 5 P ...	2 3	9 5 1 6 7 C V ...	3 5	B3103804000 ...	1 9
34768C ...	2 1	5 0 3 9 5 R ...	2 3	9 5 1 6 9 ...	2 7	B3112704000 ...	1 9
34769B ...	2 1	51250C ...	25, 35	9 5 1 7 7 ...	2 7	B3120352000 ...	1 9
34770M ...	2 1	51292F2 ...	27, 33	9 5 1 7 9 K ...	2 7	B3121804000 ...	1 9



NUMERICAL INDEX OF PARTS

<u>Part No.</u>	<u>Page No.</u>
B3126012000 ...	19
G51346KA ...	19
G52882KW ...	27, 33
GAK33034000 ...	23
GAK3303600A ...	23
GAK8403000A ...	23
NS6080210SP ...	29, 41
NS6110420SP ...	19
NS6120310SP ...	37
NS6150430SP ...	23
NS6660430SP ...	23
PH0300062C0 ...	29, 41
PH0300083U0 ...	25, 35
RE025000K0 ...	21
RM2724A ...	31
RM2871B ...	33
SD0600176SP ...	21
SM1020450TP ...	21
SM6020250TP ...	21
SM6020600TP ...	21
SS4051281SE ...	23
SS4091015SP ...	25, 35
SS4120615SP ...	39
SS4120915SP ...	41
SS4121015SP ...	37
SS4121215SP ...	37
SS4121415SP ...	33
SS4121915SP ...	29
SS6060210SP ...	25, 35
SS6060510TP ...	25, 35
SS6080610TP ...	35
SS6110610TP ...	29, 41
SS6110710TP ...	23
SS6111010SP ...	27
SS6122030SP ...	37
SS7060310SP ...	41
SS706310SP ...	29
SS7090510SP ...	25
SS7090520SP ...	19
SS7090610SP ...	25, 35
SS8080610SP ...	29, 41
SS8110520TP ...	29, 41
SS9111010SP ...	23
SS9120910TP ...	25, 35
SS9151420TP ...	23
WPO450846SP ...	29, 41
WS0410002KP ...	41
WS0510002KP ...	23, 37
WS0631510KP ...	23



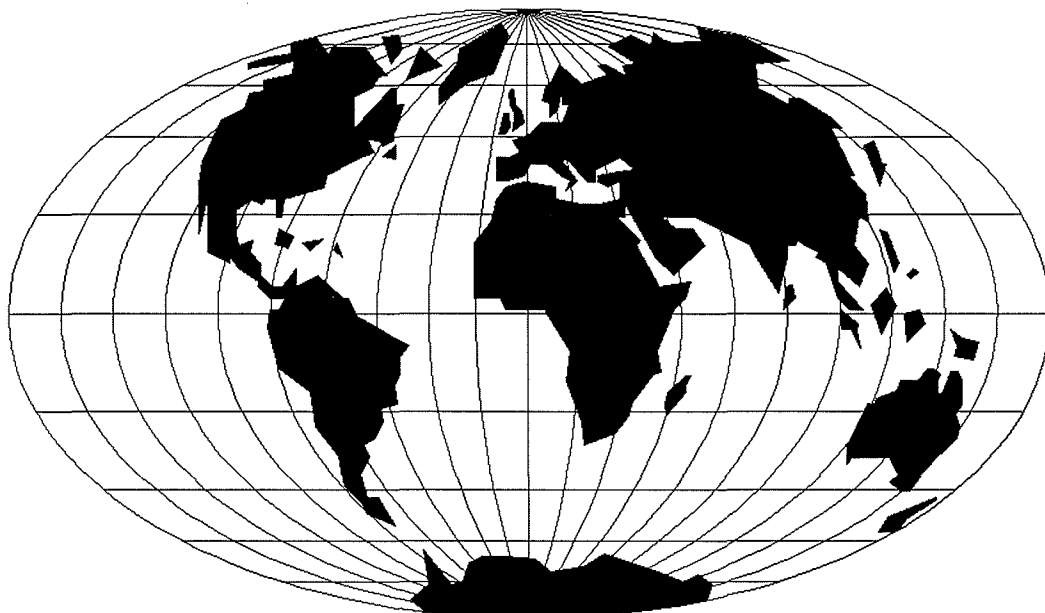

WORLDWIDE SALES AND SERVICE

Union Special Corporation maintains sales and service facilities throughout the world. These offices will aid you in the selection of the right sewing equipment for your particular operation. Union Special Corporation representatives and service technicians are factory trained and are able to serve your needs promptly and efficiently. Whatever your location, there is a qualified representative to serve you.

Corporate Office: One Union Special Plaza
Huntley, IL 60142
Phone: 847•669•5101
Fax: 847•669•1096

European Distribution Center: Union Special GmbH
Raiffeisenstrasse 3
D-71696 Möglingen, Germany
Tel: 49•07141•247•0
Fax: 49•07141•247•100

Brussels, Belgium
Charlotte, N.C.
Hong Kong, China
Huntley, IL
Leicester, England
Lille, France
Miami, FL
Milan, Italy
Möglingen, Germany
Montreal, Quebec
Osaka, Japan
Santa Fe Springs, CA
Suwanee, GA
Wayne, NJ

Other Representatives throughout
all parts of the world.

Finest Quality

JUKI
Union Special